

Technical Manual

**Operator, Unit, and Direct Support
Maintenance Manual
Including Repair Parts and Special Tools List**

**DISK HARROW
F41
WHEEL OFFSET TANDEM**

Approved for public release; Distribution is unlimited.

This technical manual is an authentication of the manufacturer's commercial literature and does not conform with the format and the content requirements normally associated with Army technical manuals. This technical manual does, however, contain all essential information required to operate and maintain the equipment.



F41
WHEEL OFFSET TANDEM
PARTS CATALOG
OPERATION - MAINTENANCE - SET-UP INSTRUCTIONS

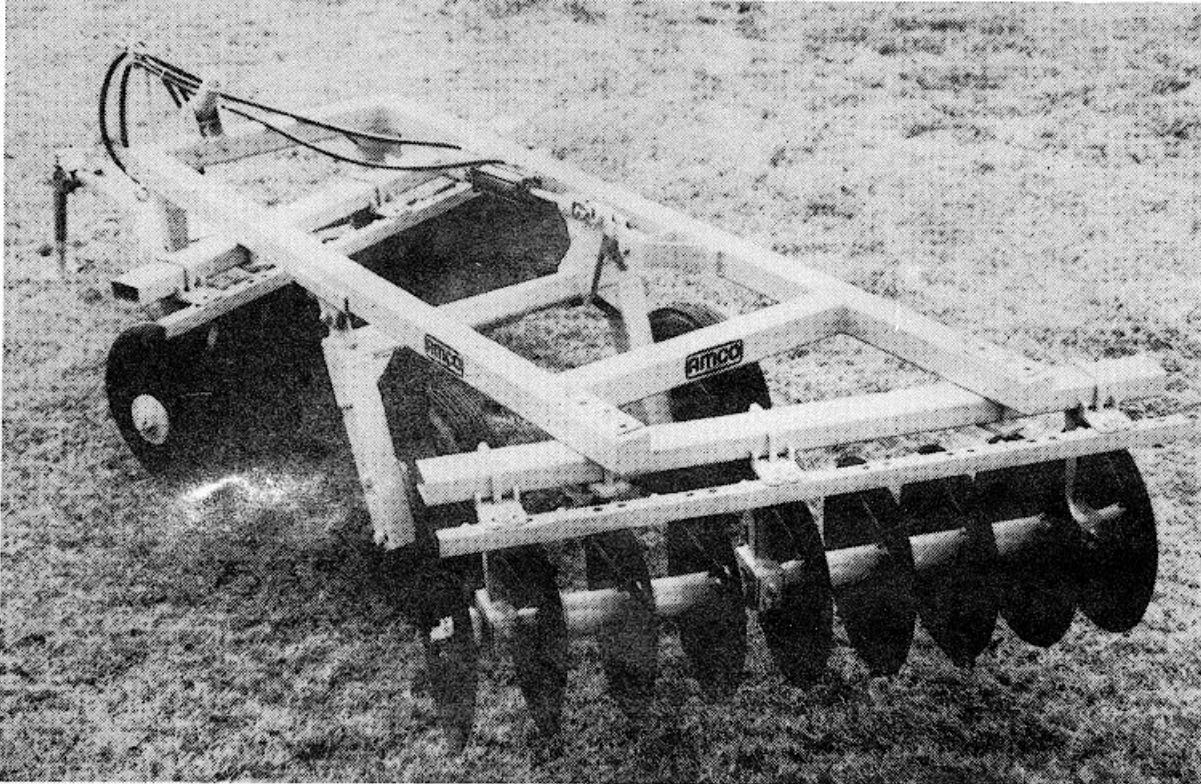

Manual Number

TM 5-3710-200-13&P

AMCO MANUFACTURING, INC.

Highway 3 Bypass — P O Box 1107 — (601) 746-4464
Yazoo City, Mississippi 39194

Safety Suggestions



THIS SAFETY ALERT SYMBOL INDICATES IMPORTANT SAFETY MESSAGES IN THIS MANUAL. WHEN YOU SEE THIS SYMBOL, CAREFULLY READ THE MESSAGE THAT FOLLOWS AND BE ALERT TO THE POSSIBILITY OF PERSONAL INJURY.



CAUTION — Never stand between tractor and disk harrow when hitching unless all controls are in neutral and the brakes are locked.



CAUTION — Park or block the disk harrow so it will not roll when disconnected from the tractor drawbar.



CAUTION — When working on disk harrows, care should be exercised in handling or tightening bolts near disk blades to avoid injury.



CAUTION — Always secure for transport by using the lock pin and the wing lock pins.



CAUTION — Never clean, adjust or lubricate a disk harrow that is in motion.



CAUTION — When transporting machinery over public roads, comply with your local and state laws regarding length, width, and lighting.



CAUTION — When trailing the harrow over public roads, the SMV Emblem must be used, for protection of tractor and motor vehicle operators.



CAUTION — When transporting farm implements on public roads after dusk it is the responsibility of the operator to provide lighting and reflectors on the rear of the implement in accordance with your state law.



CAUTION — All hydraulically or mechanically elevated operating components must be clocked to prevent accidental lowering or must be lowered to the ground when making adjustments or when the equipment is idle.

AMCO WARRANTY

AMCO Manufacturing, Inc , warrants all equipment manufactured and sold by them to be free from defects in material or workmanship under normal use and service. If any part of the equipment sold by the company proves to be defective in material or workmanship within one year from date of original sale at retail or eighteen months from date of shipment from the company's factory, except for Protect-O-Shield® bearings for which the time of warranty is two years from date of original sale of the implement, return defective equipment to the factory, transportation charges prepaid, if the company finds such equipment to be defective in material or workmanship, it will be repaired or replaced, free of charge, f o b factory. This warranty shall not be deemed to place any liability on AMCO Manufacturing, Inc , for any transportation charges, any labor or cost in the replacement of any parts.

The company assumes no liability for consequential damages of any kind and the purchaser by his acceptance of this equipment will assume liability for the consequences of its use or misuse by the purchaser, his employees or others. This warranty shall not apply to any piece of equipment or part thereof sold by this company which has been subject to any accident caused in transit, alterations by unauthorized service, negligence, abuse, or damage by flood, fire, or act of God. A defect in the meaning of this warranty in any part of said equipment shall not, when such part is capable of being removed, repaired, or replaced, operate to condemn such equipment.

This warranty shall constitute the entire warranty and/or agreement between the manufacturer and the purchaser, and the manufacturer will not be responsible for any other warranties, guarantees, representations, obligations or liabilities, either oral or written, expressed or implied.

AMCO MANUFACTURING, INC.

Yazoo City, Mississippi, U.S.A.

CONTRACT NUMBER DAAK 01-90-C-0111

TO THE PURCHASER

The care you give your new AMCO F41 Wheel Offset Disk Harrow will greatly determine the satisfaction and service you will obtain from it. By observing the instructions and suggestions in this manual, your AMCO F41 Harrow will serve you well for many years.

As an Authorized AMCO Dealer, we stock Genuine AMCO Parts, which are manufactured with the same precision and skill as the original equipment. For best performance and longer life use only Genuine AMCO replacement parts. Our factory trained staff is kept fully informed of the most efficient methods of servicing AMCO equipment and is ready and able to assist you.

When you sell your F41 Harrow, you should pass this manual on to the new owner.

If you should require additional aid or information, contact us.

YOUR AUTHORIZED AMCO DEALER

OSHA requires that you meet certain safety requirements. Become familiar with and comply with those requirements. Be sure anyone who operates this equipment understand all safety-related items. If this harrow is repainted, be certain new decals are ordered. Decals pertaining to personal safety must be replaced.



Look for this symbol to point out important safety precautions. It means ATTENTION! Become alert! Your safety is involved.

To insure efficient and prompt service, please provide the model number and serial number of your AMCO Harrow in all correspondence or contacts. Remember, the right and left hand sides of the harrow are determined by standing at the rear of the harrow and facing the direction of travel.

F41-2224 90000212 90000242
MODEL NUMBER Serial Number thru Serial Number

iii/(iv blank)

REPORTING ERRORS AND RECOMMENDING IMPROVEMENTS

You can help improve this manual. If you find any mistakes or if you know of a way to improve the procedures, please let us know. Mail your letter, DA Form 2028 (Recommended Changes to Publications and Blank Forms), or DA Form 2028-2 located in the back of this manual directly to: US Army Troop Support Command, ATTN: AMSTR-MMTS, 4300 Goodfellow Blvd., St. Louis, MO 63120-1798. A reply will be furnished to you.

Approved for public release; Distribution is unlimited.

Table of Contents

To the Purchaser iii
 Table of Contents 1
 Purpose - Capabilities - Performance 2
 General Specifications - F41 3

PARTS LIST

Main Frame, Rockshaft and Pull Tongue 4 and 5
 Hydraulic Cylinder 6 and 7
 Quick Coupler and Hydraulic Hose 8
 Hub and Wheel 9
 F41 Front Gang and Frame 10 and 11
 F41 Rear Gang and Frame 12 and 13
 Decals 14
 List of Vendors 15
 Safety Suggestions 16
 General Torque Specifications 17

OPERATORS MANUAL

Assembly Instructions 18 and 19
 Preventive Maintenance Checks and Services 20 through 22
 Lubrication 23 and 24
 Operating Instructions 25 through 30
 Maintenance and Troubleshooting 31 and 32
 Assembly Chart 33
 Appendix A. References A-1
 Appendix B. Maintenance Allocation Chart B-1
 Appendix C. Components of End Item/Basic Issue Items List C-1
 Appendix D. Additional Authorized List D-1
 Appendix E. Expendable Supplies and Materials List (To be provided at a later date.) E-1

Issued September 1990

PURPOSE

The function of the Offset Disk Harrow is to break up the ground, and turn under and incorporate residue and trash into the top soil. It is also used for leveling rough plowed ground and pulverizing lumps and clods in preparing seed bed.

Other uses include incorporation of Farm Chemicals, Construction, Road Bed preparation, Lime stabilization projects, and plowing fire lanes for fire protection in reforestation projects.

CAPABILITIES

The Offset Disk Harrows covered by this Manual will cut up to 9" depth, depending on the soil conditions and proper setting.

PERFORMANCE

Penetration of a disk harrow is obtained by angling the disk. The angle necessary for good work depends upon the conditions (or texture) of the soil and the amount of trash to be cut. On this disk harrow provision is made for angling the disk for maximum penetration which is obtained at an angle of approximately 23 degrees. When harrow is properly set for existing conditions and pulled at normal speed, the plowed ground should be fairly level.



F41 WHEEL OFFSET TANDEM

GENERAL SPECIFICATIONS

- AXLES:** 1-1/2" square high carbon, cold rolled steel
- BLADES:** 24" x 1/4" Plain with back-up blade behind right front blade
- SPACING:** 9 Inches
- SCRAPERS:** Heavy duty high carbon steel blades on 1/2 x 1-1/2" shanks mounted on 2 x 2 x 3/8 angle iron bars
- GANG ANGLE:** 17° to 23° front and rear
- TONGUE:** Adjustable, with tongue jack
- BEARINGS:** Protect-O-Shield, heavy duty 1-1/2" square bore regreasable ball type, toggle mounted
- WRENCH:** One for gang bolt
- WHEELS:** 2 - 15 x 6"
- WEIGHT:** 108-134 lbs. per blade
288-357 lbs. per foot
- TRANSPORT WIDTH:** Width of cut plus 6 Inches
- 6 - bolt hubs**

Model No.	Cutting Width	No. of Disks	No. of Bearings	Disk Size & Type	Approx. Shipping Wt.	Recommended Drawbar Horsepower
F41-2224	8'3"	22	8	24" Plain	2,930	70-85

RECOMMENDED TIRE SIZE - 9.5L x 15 - 6 or 8 Ply

NOTE

Use of disk on tractors with higher than recommended Drawbar Horsepower will cause excessive maintenance cost and may void your warranty.

**MAIN FRAME, ROCKSHAFT and
PULL TONGUE**

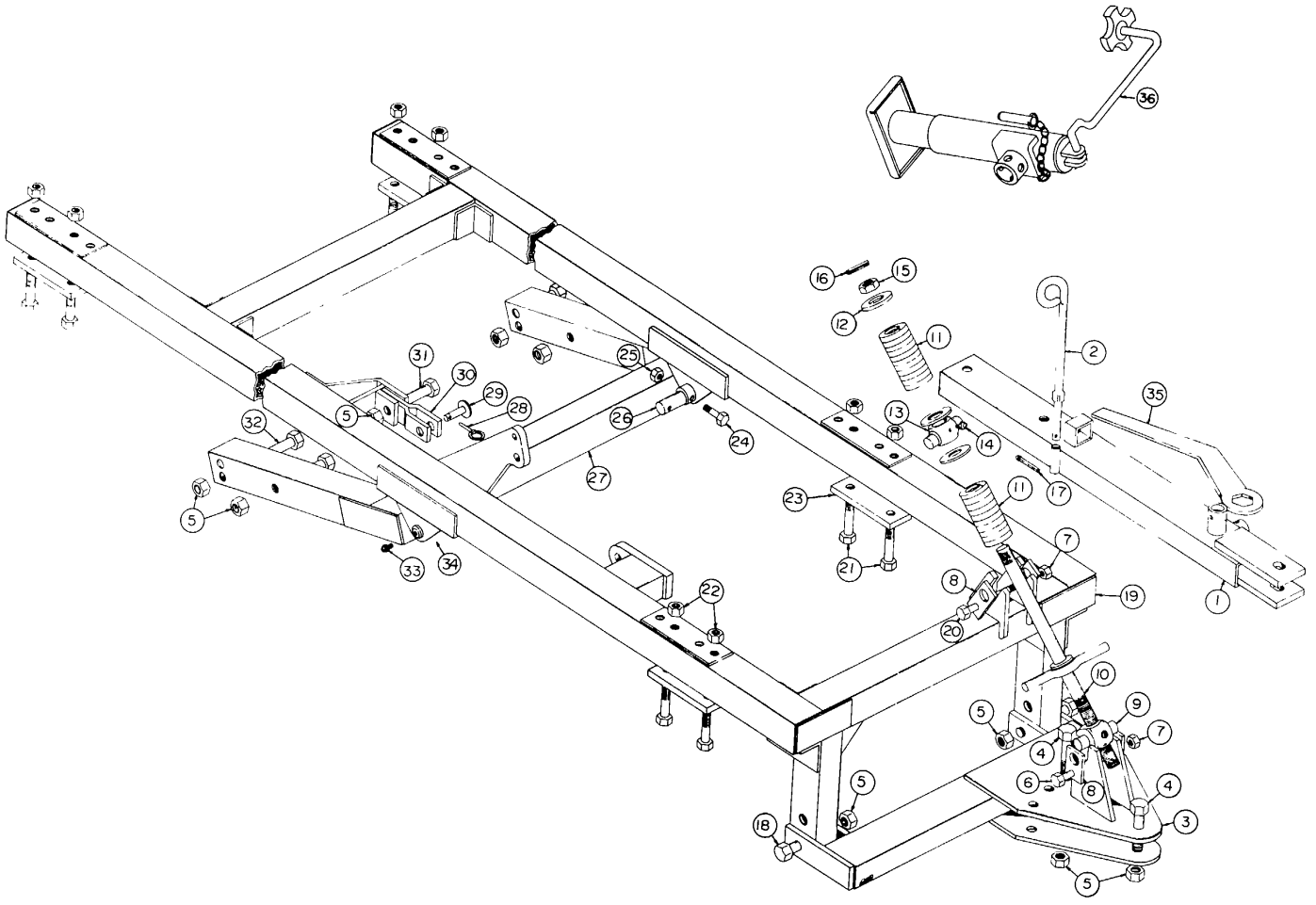

MAIN FRAME, ROCKSHAFT AND PULL TONGUE

Ref. No.	CAGEC	OEM Part No.	CAGEC	True Vendor Part No.	National Stock Number	Description	Qty.
1	OK808	20023AG				Assy. Pull Tongue	1
2	OK808	100061				Holder - Hose	1
3	OK808	20024				Assy. Cross Tongue	1
4	OK808	10672				Bolt - Hex I x 5 NC, PL	2
5	OK808	10868				Nut - Lock 1" NC, PL	9
6	OK808	10666				Bolt - 5/8 x 5 NC, PL, GR5	1
7	OK808	10299				Nut - Lock 5/8 NC, PL	2
8	OK808	9628				Clamp - Trunnion	4
9	OK808	9919A				Swivel - Stabilizer	1
10	OK808	0635A				Assy. Stabilizer Rod	1
11	OK808	10460	5V832			Spring	2
12	OK808	10872				Washer- Cut 1-3/8" PL	3
13	OK808	9892				Swivel	1
14	OK808	10606	*	5000		Fitting - Grease 1/8 NPT	2
15	OK808	11279				Nut - 1-3/8 NC, slotted	1
16	OK808	10910	**	P19-312-2250		Pin - Roll 5/16 x 2-1/4	1
17	OK808	10075				Pin - Cotter 1/4 x 1-1/2	1
18	OK808	10253				Bolt - Hex I x 5-1/2 NC, PL	2
19	OK808	20018				Assy. Main Frame	1
20	OK808	10042				Bolt - 5/8 x 6 NC, PL, GR5	1
21	OK808	10945				Bolt - Hex 7/8 x 9 NC, PL	8
22	OK808	10396				Nut - Lock 7/8 NC, PL	8
23	OK808	100583				Strap - 3/4 x 3-9-1/8 Lg	4
24	OK808	10765				Bolt - Hex 3/8x2-1/2 NC, PL, GR5	2
25	OK808	10509				Nut - Lock 3/8 NC, PL	2
26	OK808	9209				Pin - Retainer 1-1/2 Dia.-5-1/4 Lg.	2
27	OK808	20019				Assy Rockshaft	1
28	OK808	10317	9984	#1600		Pin - Klik 1/4"	1
29	OK808	0388				Assy. Pin - 3/4 Dia. x 3-1/4 Lg	1
30	OK808	0636				Assy. Transport Strap	1
31	OK808	11025				Bolt - Hex 1 x 3 NC, PL, GR5	1
32	OK808	10181				Bolt - Hex I x 6 NC	4
33	OK808	11081	*	5031		Fitting - Grease	2
34	OK808	9270				Bushing - Bronze 1-3/4 OD x 1-1/2 ID x 2 Long	2
35	OK808	100134	IDM35	#61965		Wrench - Nut	1
36	OK808	11261	***	01054100		Jack - Parking	1

* See Page 15 Vendor No 1

** See Page 15 Vendor No 10

*** See Page 15 Vendor No 2

HYDRAULIC CYLINDER

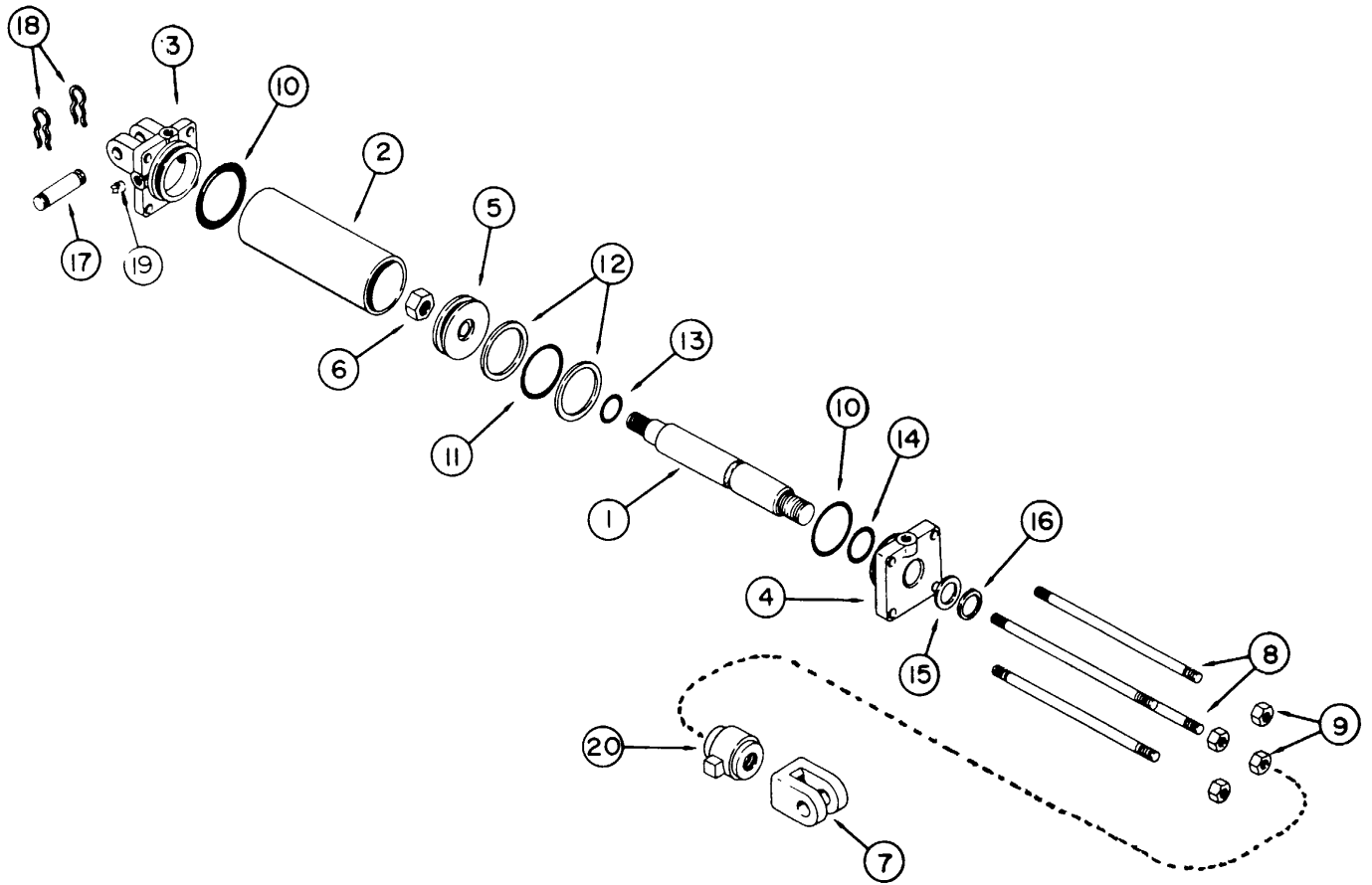

HYDRAULIC CYLINDER (4 X 8)

Ref. No.	CAGEC	OEM Part No.	CAGEC	True Vendor Part No.	National Stock Number	Description	Qty.
1	OK808	10965	29260	010800005		Rod - Piston	1
2	OK808	10966	29260	051900008		Tube	1
3	OK808	10952	29260	141900006		Butt	1
4	OK808	10967	29260	081900006		Gland	1
5	OK808	10968	29260	071900006		Piston	1
6	OK808	10980	29260	220000210		Lock Nut -1" 14NF	1
7	OK808	11296	29260	100000051		Clevis for 1-1/4 Dia Pin	1
8	OK808	10970	29260	170301133		Rod -Tie	4
9	OK808	10187				Nut - Hex 5/8 NC, PL	4
17	OK808	10956	29260	190400004		Pin - Clevis	2
18	OK808	10957	29260	190400001		Clip	4
19	OK808	10978	29260	200200021		Pipe Plug	1
20	OK808	10937	29260	PMSC-3		Control - Stroke	1
21	OK808	10976	29260	PMCK-8600		Kit - Seal Repair	1
*10	OK808	10958					2
* 11	OK808	10959				O-Ring	1
*12	OK808	10960				Washer	2
*13	OK808	10971				O-Ring	1
*14	OK808	10972				O-Ring	1
*15	OK808	10973				Washer	1
*16	OK808	10974				Wiper	1
*		10975				O-Ring (Not shown in illustration)	1
	OK808	11492	**	125-100-100		Bushing - Split (For Clevis - Not Shown)	2
	OK808	BD-20-0003	29260			4 x 8 Cylinder complete with Stroke Control	

** See Page 15 Vendor No 10

*NOTE. Seal Repair Kit Parts Available in Repair Kits Only

**AMCO F41
QUICK COUPLER AND HYDRAULIC HOSE**

Ref. No.	CAGEC	OEM Part No.	CAGEC	True Vendor Part No.	National Stock Number	Description	Qty.
1	OK808	12079	*	W43K-24-24		Female Pipe Flange Pad Kit (includes W43, O-ring, and all mounting hardware)	2
2	OK808	12080	*	540624-8		Hex Reducer Bushing	2
3	OK808	10921	**	1501-8-8		90° Swivel Elbow 1/2 NPT Male to 1/2 NPT Female	2
4	OK808	11320	*-*	08BHAHA132		1/2 x 11' Hydraulic Hose with 1/2" NPT fittings	1
5	OK808	10720	***	08BHAHA144		1 1/2 x 12' Hydraulic Hose with 1/2" NPT fittings	1
	OK808	AB-20-0001				Bundle Hose Kit Reference 1 - 5	

* See Page 15 Vendor No. 6
 ** See Page 15 Vendor No. 7
 *** See Page 15 Vendor No. 8

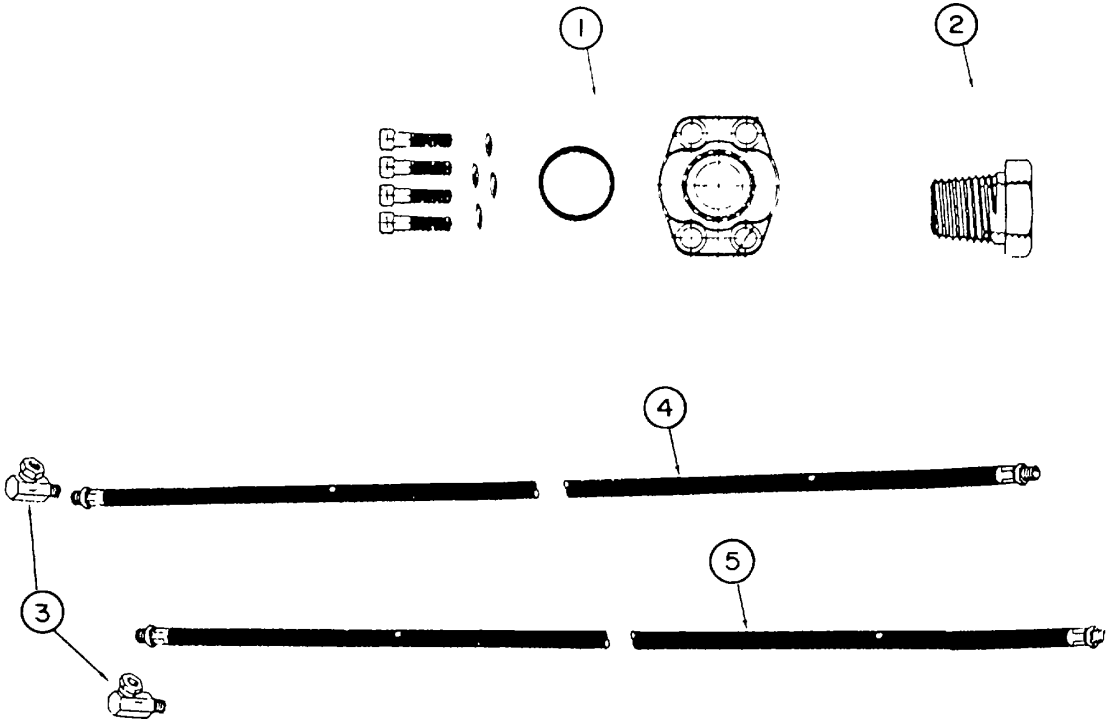

**AMCO F41
HUB AND WHEEL**

Ref. No.	CAGEC	OEM Part No.	CAGEC	True Vendor Part No.	National Stock Number	Description	Qty.
6	OK808	10253				Bolt - Hex	4
7	OK808	10868				Nut - Lock	4
8	OK808	1475				Support - Wheel	2
9	OK808	11017	1GD20	SL-175-1		Seal - Grease	2
10	OK808	10353	2H736	LM48548		Cone -- Inner	2
11	OK808	11644	1GD20	1-25660F-02-00		Hub w/Cup and Lugs	2
11	OK808	10352	2H736	LM48510		Cup - Inner	2
11	OK808	10293	2H736	LM67010		Cup - Outer	2
11	OK808	11299	*	9135761		Bolt - Hub	12
11	OK808	11046	1GD20	STN-509		Nut - Hub Bolt	12
12	OK808	10295	2H736	LM67048		Cone - Outer	2
13	OK808	10263				Washer - Spindle	2
14	OK808	10264				Nut - Spindle	2
15	OK808	10291				Pin - Cotter	2
16	OK808	10356	1GD20	1604		Cap - Hub	2
17	OK808	10265	20076	0411141		Wheel - 15 x 6	2

* See Page 15 Vendor No. 9

HUB and WHEEL

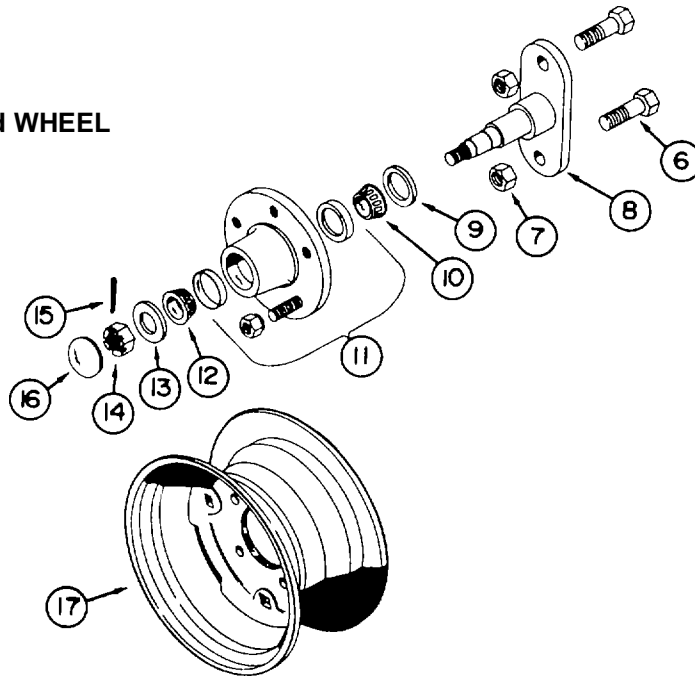

FRONT GANG - F41

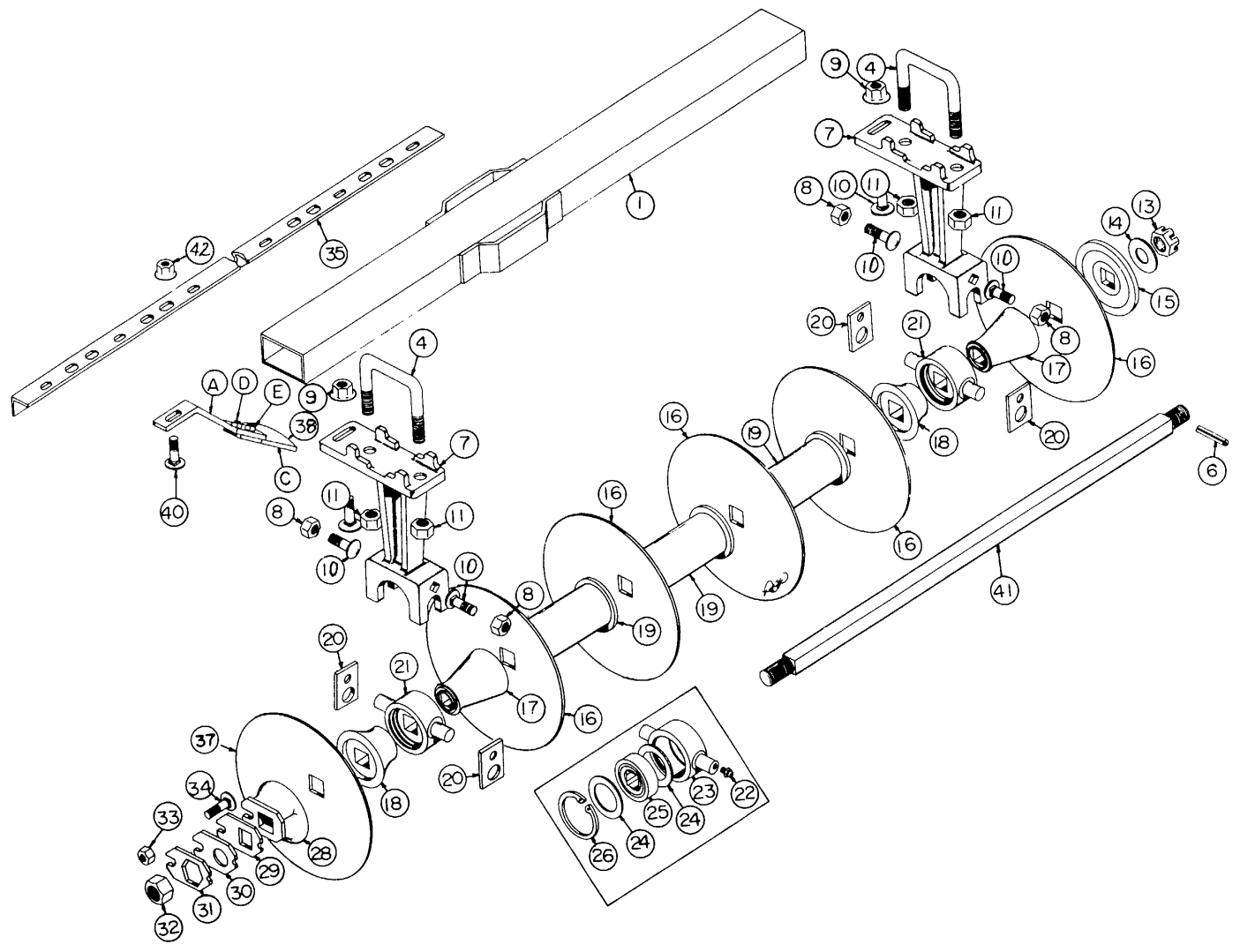

**AMCO F41
FRONT GANG AND FRAME**

Ref. No.	CAGEC	OEM Part No.	CAGEC	True Vendor Part No.	National Stock Number	Description	Qty.
1	OK808	20066				Assy Gang Frame	1
4	OK808	11280				"U" Bolt 7/8" Diameter	4
6	OK808	10910	*	P19-312-2250		Roll Pin 5/16 x 2-1/4	2
7	OK808	16012A				Bearing Riser	4
8	OK808	10299				Lock Nut 5/8, NC, PL	8
9	OK808	11647				Flg Lock Nut 5/8, NC, PL, GRG	4
10	OK808	10135				Carriage Bolt 5/8 x 1-3/4, NC, PL	12
11	OK808	10396				Lock Nut 7/8 NC, PLT	8
13	OK808	10226				Nut 1-1/2" NF, Slotted	2
14	OK808	10872				Cut Washer, 1-3/8 PLT	2
15	OK808	2404				Bumper Washer	2
16	OK808	3255	**			Blade 24" x 1/4 Plain	10
17	OK808	17014				End Bell-Small	4
18	OK808	17010				End Bell-Large	4
19	OK808	0522				Spacer Spool	5
20	OK808	9628				Clamp Trunnion	8
21	OK808	FB-09-0015				Bearing and Housing Assembly	4
22	OK808	10606	***	5000		Grease Fitting 1/8 NPT	1
23	OK808	16003				Housing-Bearing	1
24	OK808	100104				Washer 100mm	2
25	OK808	11503	01212	DC211TTR4		Bearing	1
26	OK808	11064	****	IN-400		Snap Ring	1
28	OK808	1222A				End Washer	2
29	OK808	100099				Spacer Plate	2
30	OK808	100098				Bearing Plate	2
31	OK808	5622A				Lock Plate	2
32	OK808	10489				Nut 1-1/2 NF	2
33	OK808	10395				Lock Nut 1/2 NC, PLT	2
35	OK808	100534				Scraper Bar	1
37	OK808	3276				Blade 22" x 1/4 Plain	1
38	OK808	0788				Assembly Scraper-R.H	10
A	OK808	100271				Scraper Shank	1
C	OK808	100270				Scraper Blade	1
D	OK808	11652				Hex Bolt 1/2 x 1-1/4 NC, PL, GR5	2
E	OK808	10395				Lock Nut 1/2 NC, PL	2
40	OK808	10870				Carr Bolt 1/2 x 1-1/2 NC, PL, GR5	10
41	OK808	9441				Gang Bolt	1
41	OK808	9442				Gang Bolt	1
	OK808	3278	*****			Blade-Back Up 10 x 11 GA	1
42	OK808	11646				Fig. Lock Nut 1/2 NC, PL, GRG	10

- * See Page 15 Vendor No. 10
- ** See Page 15 Vendor No. 3
- *** See Page 15 Vendor No. 1
- **** See Page 15 Vendor No. 4
- ***** See Page 15 Vendor No. 5

REAR GANG - F41

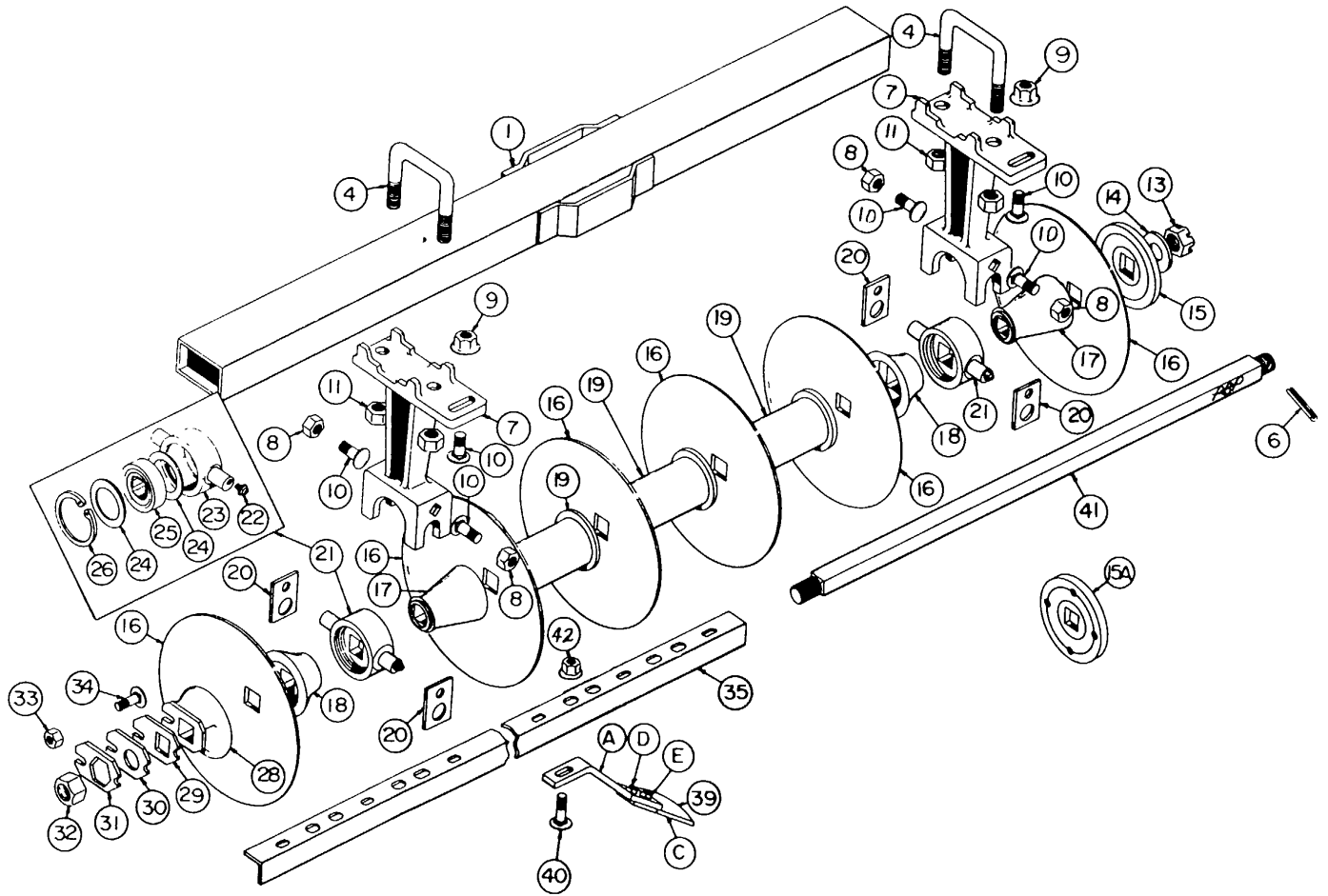

**AMCO F41
REAR GANG AND FRAME**

Ref. No.	CAGEC	OEM Part No.	CAGEC	True Vendor Part No.	National Stock Number	Description	Qty.
1	OK808	20066				Assembly Gang Frame	1
4	OK808	11280				U-Bolt 7/8 Diameter	4
6	OK808	10910	*	P19-312-2250		Roll Pin 5/16 x 2-1/4	2
7	OK808	16012A				Bearing Riser	4
8	OK808	10299				Lock Nut 5/8 NC, PL	12
9	OK808	11647				Fig. Lock Nut, 5/8, NC, PL, GRG	4
10	OK808	10135				Carr. Bolt 5/8 x 1-3/4, NC, PL	12
11	OK808	10396				Lock Nut 7/8 NC, PL	8
13	OK808	10226				Nut 1-1/2", NF, Slotted	2
14	OK808	10872				Cut Washer 1-3/8 PL	2
15	OK808	2404				Bumper Washer	1
16	OK808	3255	**			Blade - 24" x 1/4" PL	11
17	OK808	17014				End Bell-Small	4
18	OK808	17010				End Bell-Large	4
19	OK808	0522				Spacer Spool	5
20	OK808	9628				Clamp Trunnion	8
21	OK808	FB-09-0015				Bearing and Housing Assembly	4
22	OK808	10606	***	5000		Grease Fitting 1/8 NPT	1
23	OK808	16003				Housing Bearing	1
24	OK808	100104				Washer 100mm	2
25	OK808	11503	01212	DC211TTR4		Bearing	1
26	OK808	11064	****	IN-400		Snap Ring	1
28	OK808	1222A				End Gang Washer	2
29	OK808	100099				Spacer Plate	2
30	OK808	100098				Bearing Plate	2
31	OK808	5622A				Lock Plate	2
32	OK808	10489				Nut 1-1/2 NF	2
33	OK808	10395				Lock Nut 1/2 NC, PL	2
34	OK808	10710				Carriage Bolt 1/2 x 2, NC, PL	2
35	OK808	100534				Scraper Bar	1
39	OK808	0789				Assembly Scraper LH	10
A	OK808	100271				Scraper Shank	1
C	OK808	100270				Scraper Blade	1
D	OK808	11652				Hex Bolt 1/2 x 1-1/4 NC, PL, GR5	2
E	OK808	10395				Lock Nut 1/2 NC, PL	2
40	OK808	10870				Carr Bolt 1/4 x 1-1/2 NC, PL, GR5	10
41	OK808	9441				Gang Bolt	1
41	OK808	9442				Gang Bolt	1
42	OK808	11646				Fig. Lock Nut 1/2 NC, PL, GRG	10

* See Page 15 Vendor No. 10

** See Page 15 Vendor No. 3

*** See Page 15 Vendor No. 1

**** See Page 15 Vendor No. 4

Amco F41 Decals

Ref. No.	Part No.	Description	No. Req'd
1	11465	DECAL - AMCCO.....	3
2	11741	DECAL - Warning	1
3	11716	DECAL - Maintenance	1

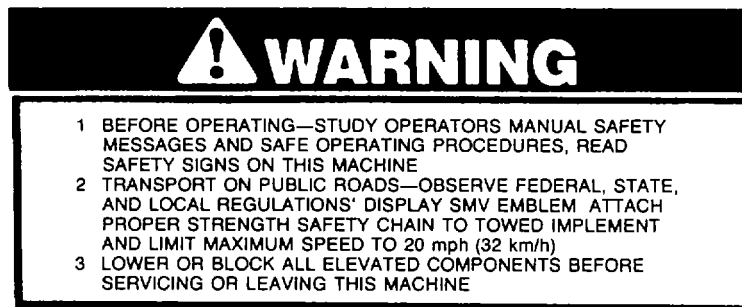

MAINTENANCE INSTRUCTIONS

1. Keep all bolts tight. Check after first 50 hours or one week's operation.. Visually inspect all bolts daily.
2. Keep wheel bearings properly adjusted. Clean and repack each season or every 300 hours. Replace **all** worn or damaged parts when repairing.
3. Keep gang bolts tight! Tighten after first day's operation Do not run with loose disk blades. If gang bolts have been operated in a loose condition, retighten, then tighten again after 30 minutes use, again after 4 to 5 hours, and again after 8 to 10 hours.

4. Grease gang bearings **daily** with a hand grease gun and a good grade of clean, number 2, lithium soap base grease. Always wipe fittings clean before greasing. Apply grease until. old or dirty grease is purged from bearings. Avoid high-pressure greasing.
5. Inspect for damaged or misaligned parts if gangs to not turn smoothly by hand. Bearings will fall prematurely if operated with misaligned or damaged gang parts. If a gang is operated for one or more hours following a bearing failure replace all bearings on the gang.

Refer to the operator's manual for other important maintenance instructions.

11716

LIST OF VENDORS

- 1 - YOUNG & VANN
P. O. Box 11485
Birmingham, AL 35202-1485
- 2 - SPECIAL PRODUCTS
15000 W. 44th Avenue
Golden, CO 80403-1824
- 3 - SOUTHERN MARKETING AFFILIATES
P. O. Box 2247
Jonesboro, AR 72401
- 4 - PROSPECT FASTENERS
520 Business Center Drive
Mt. Prospect, IL 60056
- 5 - INGERSOLL PRODUCTS CORPORATION
1000 West 120th Street
Chicago, IL 60643
- 6 - K. R. JOHNSON, INC.
15547 W. 109th Street
Lenexa, KS 66215
- 7 - BRENNAN INDUSTRIES, INC.
5360 Snapfinger Woods Drive
Decatur, GA 30035
- 8 - HYTEK HOSE & COUPLING
451 E. Hupp Road
Kingsbury, IN 46345-0072
- 9 - WILTON CORPORATION
Rt. 1 - Industrial Park
Winchester, TN 37398
- 10 - VOGELSANG CORPORATION
435 Industrial Way West
Eatontown, NJ 07724

Safety Suggestions



THIS SAFETY ALERT SYMBOL INDICATES IMPORTANT SAFETY MESSAGES IN THIS MANUAL. WHEN YOU SEE THIS SYMBOL, CAREFULLY READ THE MESSAGE THAT FOLLOWS AND BE ALERT TO THE POSSIBILITY OF PERSONAL INJURY.



CAUTION — Never stand between tractor and disk harrow when hitching unless all controls are in neutral and the brakes are locked.



CAUTION — Park or block the disk harrow so it will not roll when disconnected from the tractor drawbar.



CAUTION — When working on disk harrows, care should be exercised in handling or tightening bolts near disk blades to avoid injury.



CAUTION — Always secure for transport by using the lock pin and the wing lock pins.



CAUTION — Never clean, adjust or lubricate a disk harrow that is in motion.



CAUTION — When transporting machinery over public roads, comply with your local and state laws regarding length, width, and lighting.



CAUTION — When trailing the harrow over public roads, the SMV Emblem must be used, for protection of tractor and motor vehicle operators.









CAUTION — When transporting farm implements on public roads after dusk it is the responsibility of the operator to provide lighting and reflectors on the rear of the implement in accordance with your state law.



CAUTION — All hydraulically or mechanically elevated operating components must be clocked to prevent accidental lowering or must be lowered to the ground when making adjustments or when the equipment is idle.

GENERAL TORQUE SPECIFICATION TABLE

ALL BOLTS SHOULD BE TIGHTENED TO THE
RECOMMENDED TORQUES SHOWN IN THE
"GENERAL TORQUE SPECIFICATION TABLE"

GENERAL TORQUE SPECIFICATION TABLE							
USE THE FOLLOWING TORQUES WHEN SPECIAL TORQUES ARE NOT GIVEN							
Note: These values apply to fasteners as received from supplier, dry, or when lubricated with normal engine oil. They do not apply if special graphited or moly-disulphide greases or other extreme pressure lubricants are used. This applies to both UNF and UNC threads.							
SAE Grade No		2		5		8 *	
Bolt head identification marks as per grade NOTE: Manufacturing Marks Will Vary				  		  	
		Torque		Torque		Torque	
Bolt Size		Foot Pounds		Foot Pounds		Foot Pounds	
Inches	Millimeters	Min	Max	Min	Max	Min	Max
1/4	6 35	5	6	9	11	12	15
5/16	7 94	10	12	17	20 5	24	29
3/8	9 53	20	23	35	42	45	54
7/16	11 11	30	35	54	64	70	84
1/2	12 70	45	52	80	96	110	132
9/16	14 29	65	75	110	132	160	192
5/8	15 88	95	105	150	180	220	264
3/4	19 05	150	185	270	324	380	456
7/8	22 23	160	200	400	480	600	720
1	25 40	250	300	580	696	900	1080
1 1/8	25 58			800	880	1280	1440
1 1/4	31 75			1120	1240	1820	2000
1 3/8	34 93			1460	1680	2380	2720
1-1/2	38 10			1940	2200	3160	3560

* Thick nuts must be used with Grade 8 bolts

Assembly Instructions for F41 Harrow

The AMCO F41 series disk harrow is shipped from the factory with maximum preassembly in the following bundles:

1. Main frame, rockshaft, cross tongue, and pull tongue.
2. Two gang and frame bundles with scrapers and scraper bars installed.
3. Two 15 x 6 - 6 bolt wheels.

ASSEMBLY PROCEDURE:

1. Place all bundles where they will be convenient. Arrange loose parts so they may be readily seen when needed. To insure good alignment of units and parts, insert all bolts leaving the nuts slightly loose. Tighten the nuts evenly to prevent misalignment, distortion, or binding. Be sure all bolts are tight, all cotter pins properly spread, and all pins properly inserted.
2. Select a clean level area for assembly. Place the main frame on sturdy stands.
3. The cross tongue should be located in the set of holes on the main frame that will best match the pull tongue to the tractor drawbar height.



CAUTION -- Use sturdy stands to prevent frame from falling.

4. Attach stabilizer to the hitch control bracket and hitch on cross tongue.
5. Attach hose holder to hitch tongue.
6. Attach tongue jack to hitch tongue.
7. Mount tires and tubes on 15 x 6 wheels. Inflate tires. 9.5L x 15 tires are recommended. Bolt the wheels to the hubs. Tighten hub bolts evenly to assure wheel alignment. The left wheel mounts inside the main frame. The right wheel mounts to the right of the main frame.
8. Install a 4 x 8 hydraulic cylinder with stroke control (optional) to the harrow. Connect hydraulic hoses from the cylinder to the tractor.

Attach the pull tongue to the tractor drawbar.

9. Raise the harrow up on the wheels by activating the hydraulic cylinder.

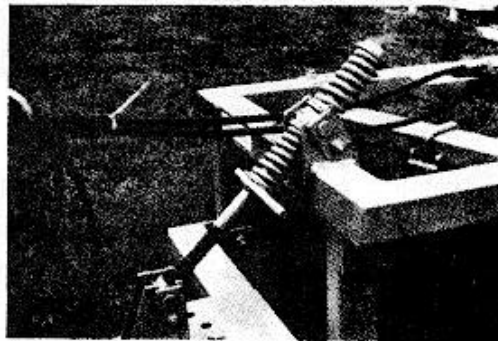

CAUTION When working on disk harrows care should be exercised in handling or tightening bolts near disk blades to avoid injury. All hydraulically or mechanically elevated components must be blocked or lowered to prevent accidents when servicing the harrow.

10. Remove gang clamp from the main frame. Attach the gang assemblies to the main frame. Secure the with clamp plates and 7/8" diameter bolts. Convex end of the gang faces to the left on the front gang and to the right on the rear gang.
11. Tighten bolts snug but not tight. For proper placement of the gang frame on the main frame, refer to the chart and drawing at the end of these instructions. Dimension "A" is measured from the outside of the main frame, along the center line of the gang frame to the inside of the "U" bolt.
12. Check and tighten all bolts. Be sure all cotter pins are properly spread and all pins in place. Check the gangs to see that they rotate freely.
13. Be sure that the harrow is properly lubricated.
14. Adjust the harrow for front to rear leveling.
15. The tongue jack should be mounted on top of the pull tongue when using the harrow to prevent damage and to secure the gang bolt wrench in place.

OPERATOR PREVENTIVE MAINTENANCE CHECKS AND SERVICES (PMCS)

INTRODUCTION

This section contains information on the PMCS that you must perform to keep the Disk Harrow in good working condition.

- (1) Before You Operate. Always keep in mind the CAUTIONS and WARNINGS you find in this manual and on the equipment. Perform the "Before Operation" (B) PMCS shown in Table 1.
- (2) While You Operate. Always keep in mind the CAUTIONS and WARNINGS you find in this manual and on the equipment. Perform the "During Operation" (D) PMCS shown in Table 1.
- (3) After You Operate. Perform the "After Operation" (A) PMCS shown in Table 1.
- (4) If Your Equipment Fails to Operate. Troubleshoot with the proper equipment. Report any deficiencies using the proper forms. See DA PAM 738-750.

OPERATOR PMCS PROCEDURES

- a. The procedures in Table 1 will help you keep the Disk Harrow in good operating condition.
- b. To use the PMCS table, you will need to know what the numbers and letters on the table mean. Following is an explanation of each column of the table.

- (1) Item Number-The order in which you perform checks on the Disk Harrow equipment. You use this column as a source of item numbers for the "TM Number" column on DA Form 2404, Equipment Inspection and Maintenance Worksheet, in recording results of PMCS.
- (2) Interval A dot (e) in the proper column shows when you make your check.

B-before you begin operation

D-while you operate

W-weekly

S-semiannually

- (3) Item to be Inspected the item you should inspect.
- (4) Procedure a brief description of how you make your check or what to do.
- (5) Equipment is not ready/available if this column contains criteria that makes the equipment not ready/available because of inability to perform its primary mission. An entry in this column will: identify conditions that make the equipment not ready/available for readiness reporting. Deny use of the equipment until corrective maintenance has been performed.

REPORTING AND CORRECTING DEFICIENCIES

You may find troubles that you cannot handle. List them on the proper maintenance forms. DA Form 2408-1 is the Equipment Daily or Monthly log, DA Form 2404 is the Equipment Inspection and Maintenance Worksheet, and DA Form 2407 is the Maintenance Request Form. Tell your supervisor.

SPECIAL INSTRUCTIONS

Leakage definitions for operator/crew PMCS are classified as follows:

- Class I Seepage of fluid (as shown by wetness or discoloration) not great enough to form drops.
- Class II Leakage of fluid great enough to form drops but not great enough to cause drops to drip from the inspected item.
- Class III Leakage of fluid great enough to form drops that fall from the inspected item.

CAUTION

Equipment operation is allowable with minor leakages (Class I or II). Of course, you must consider the fluid capacity of the item/system being inspected. When in doubt, ask your supervisor. When operating with Class I or Class II leaks, continue to check fluid level as required in your PMCS procedures. Do not operate equipment with a Class III fluid leak. Report Class III leaks to your supervisor or organizational maintenance.

TABLE 1. OPERATOR PREVENTIVE MAINTENANCE CHECKS AN(] SERVICES (PMCS)

B Before Operation
D -During Operation

W Weekly
S Semiannually

Item No.	Interval				ITEM TO BE INSPECT PROCEDURE	Equipment is Not Ready Available If:
	B	D	W	S		
1		•			<p>Disk Harrow</p> <p>a. Visually inspect all bolts for security.</p> <p>b. Check wheel bearings for excessive end play.</p> <p>c. Repack wheel bearings and adjust spindle nuts.</p> <p>d. Grease rockshaft retainer pins.</p> <p>e. Grease hitch stabilizer. Clean and oil stabilizer rod threads.</p> <p>f. Ensure that gang bolts are tight.</p> <p>g. Grease gang bearings.</p> <p>h. Inspect gangs for damaged or misaligned parts if gangs do not turn smoothly by hand.</p> <p>i. Visually inspect hydraulic system for damage or oil leaks.</p> <p>j. Check scrapers for proper adjustment.</p>	<p>Bolts are loose.</p> <p>Wheel bearings have failed or spindle nuts need adjustment.</p> <p>Disk blades or gang bolts are loose.</p> <p>Gangs are damaged, misaligned or have a bearing failure.</p> <p>Harrow does not raise or hold raised position.</p>

Lubrication of F41

Careful and regular attention to lubrication will greatly increase the life of the harrow. For economical and efficient operation, the proper lubrication of frame fittings, gang bearings, and wheel bearings is essential.

Be sure fittings are free of dirt before greasing. If a fitting is lost or damaged, replace it immediately. Lubricate all parts thoroughly with a good grade No. 2 gun grease (Lithium Base).

Miscellaneous working parts not provided with lubrication fittings should be oiled occasionally with a good grade of lubrication oil.

ROCKSHAFT RETAINER PINS: Grease every week or 50 hours of operation.

GANG BEARINGS: The AMCO wheel type offset disk harrow is equipped with triple sealed regreasable ball bearings. The bearings are packed and greased at the factory. Grease these bearings every week or 50 hours of operation. **IMPORTANT** apply grease with a low pressure, low volume hand grease gun. Use care to prevent damage to bearing seals. At the end of the season, all bearings should be greased, then raise the harrow on its wheels and spin the gangs slowly so that grease wraps around the bearing seals. This will help protect the seals from the elements during periods of storage.

HITCH: The hitch stabilizer should be greased every week or 50 hours of operation. The stabilizer should also be greased at the start of each season and at the end of each season. The threads on the stabilizer rod should be cleaned out and oiled occasionally for smooth operation.

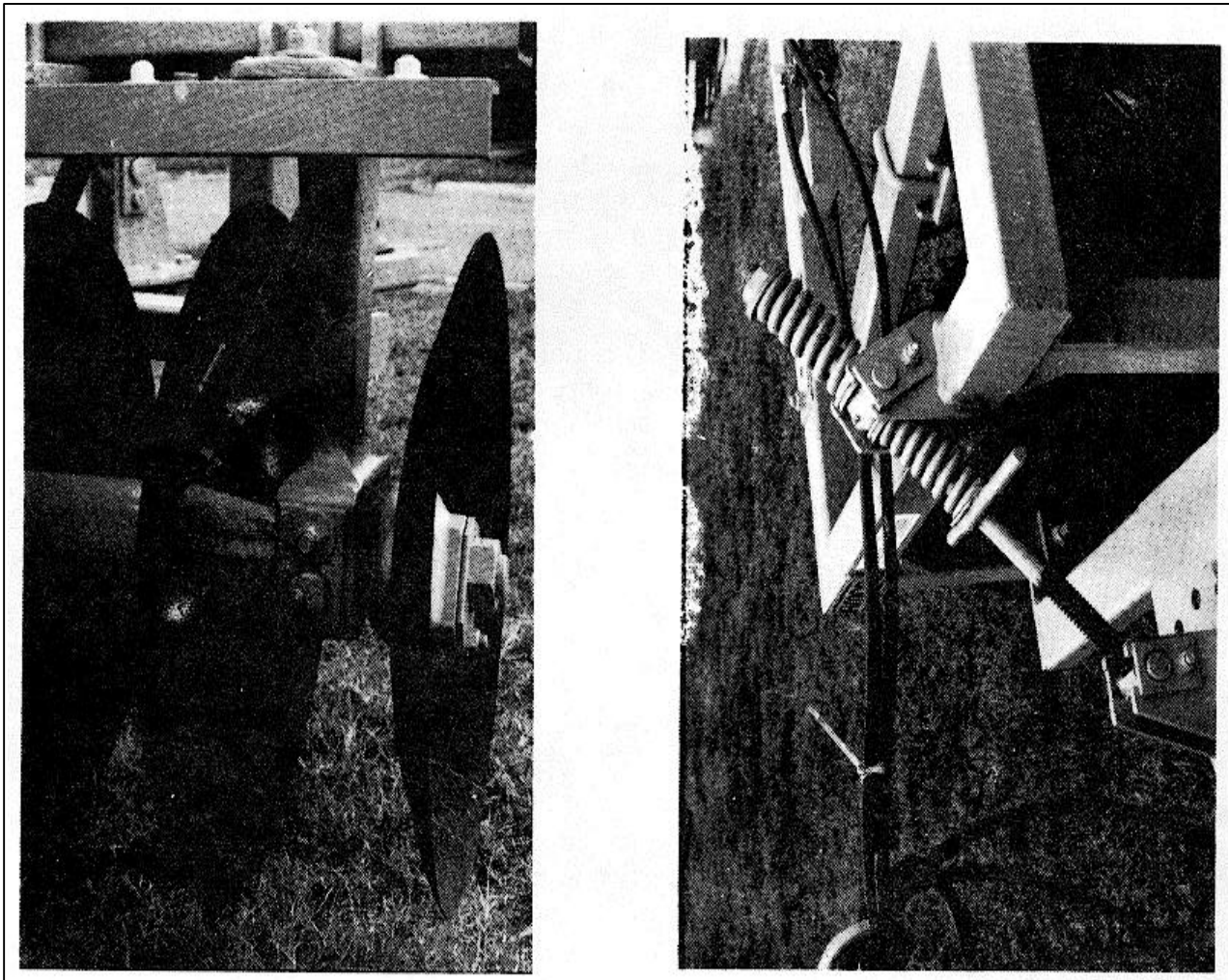

WHEEL BEARINGS: The wheel hubs are equipped with tapered roller bearings. These hubs are packed with grease and adjusted at the factory. They should be repacked and the spindle nut properly adjusted each season or every 300 hours of operation. Use a good grade No. 2 gun grease (Lithium Base).

Wheel bearings should be repacked with grease and adjusted annually. Under extreme conditions, they should be serviced more frequently. Check occasionally for excessive end play. Adjust as required to eliminate excessive end play.

To disassemble the hub, remove the wheel, then remove the dust cap by prying around it. Remove the cotter pin, slotted nut, and flat washer. Carefully remove the hub and bearings from the spindle. Thoroughly clean and carefully inspect all parts for wear. All parts that appear to be worn or damaged must be replaced.

Use the following procedure when repairing or servicing wheel hubs:

1. Clean all parts that are to be re-used.
2. Carefully inspect the metal case on the grease seal. Discard the seal if the case is bent or damaged. Check seal lips for cuts, tears, or excessive wear. Seal must fit snugly on extended inner race of bearing.
3. Carefully inspect both sets of bearing cones. Bearing bore and rollers must be smooth and free of nicks and scratches. Replace cones if damaged.
4. Inspect hub to make sure that the hub holes have a full thread. Bearing cones must be smooth and free of surface blemishes. Cups must be removed from the hub and replaced if damaged. Cups should be fully pressed into the hub and rest squarely against the shoulder inside the hub. Hub cap and grease seal should fit snugly inside the hub. Severely damaged hubs should be replaced.
5. Threads on spindle must be in good condition. Bearing cone seats must be smooth and free of blemishes. Bearing cones must fit squarely on the spindle.
6. Flat washer, slotted nut, cotter pin and hub cap must be in good condition. Replace if worn or damaged.

To reassemble the hub, repack each bearing cone with grease and fill the hub cavity 1/3 full of grease. Place inner bearing assembly in hub, press grease seal into hub and carefully re-install the hub on the spindle. Install the outer bearing assembly into the hub and replace the flat washer and slotted nut. Tighten the slotted nut to seat the bearings, until the hub binds when rotated.

Back the slotted nut to the nearest slot. Rotate the hub five or six revolutions in each direction to seat all parts. Retighten the slotted nut while rotating the hub. When the hub binds, back the nut off to the nearest slot, and install the cotter pin. Install the hub cap, and re-mount the wheel on the hub.

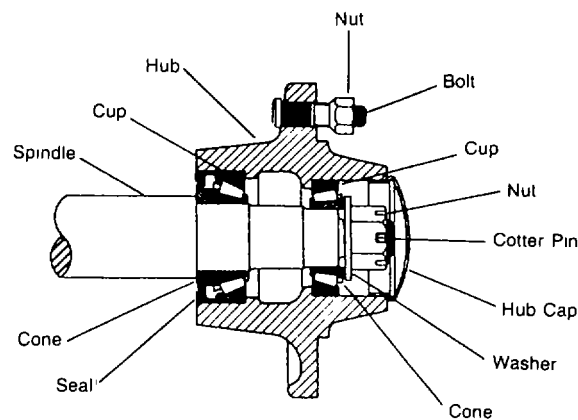

Operating Instructions for F41 Harrow

Your new AMCO offset disk harrow has been set up, inspected, and adjusted by your dealer before delivery. However, before using your new harrow, or one that has been stored, check to make certain that all nuts and bolts are tight, all cotter pins spread, and that the harrow has been lubricated.

This instruction manual should be carefully and thoroughly read to enable the operator to care for and operate the harrow.

The right and left hand sides of the harrow are determined by standing at the rear of the harrow and facing the direction of travel.

Refer to your tractor operator's manual for complete tractor operating instructions.

ADJUSTMENT FOR LEVEL DISKING: It is recommended that the tractor be operated at a speed best suited for soil conditions. High-speed disking will sometimes result in excessive lateral movement of the soil. This may leave an uneven surface behind the disk harrow known as "ridging" or "furlowing".

When disking in a cover crop or where the land is to be reworked, an uneven surface is not objectionable. If the land is to be bare through the winter, furrows and ridges will reduce soil washing, and will help catch and hold moisture, resulting in more water being absorbed by the soil.

FEATHERING BLADES: The use of feathering blades with smaller disks will move the excess soil back which is thrown out by the front gangs at high speeds. By using the feathering blades, the outside furrows are partially filled, giving a more uniform job of disking.

GROUND SPEED AND ADJUSTMENTS: Where it is necessary to have a level job of disking, the following factors must be taken into consideration: (1) tractor speed, (2) hitch adjustment, and (3) disk gang angle adjustment.

TRACTOR DRAWBAR: It is suggested that the tractor drawbar be set so it is free to swing when disking. This will prevent side draft, making operation of the harrow easier. The tractor drawbar will pull somewhat to the left side during operation. This is normal with an offset harrow.

HARROW HITCH: The harrow pull tongue can be offset to the right or left by using the set of holes in the cross tongue plates to obtain the desired offset.

SPRING LOADED STABILIZER: Penetration of front and rear gangs may vary. The spring loaded stabilizer may be adjusted to level the harrow front rear. In extremely hard ground it may be necessary shorten the stabilizer to force the front or penetrating gang into the ground. In normal conditions, the stabilizer should be adjusted so that the disk harrow level front to rear while disking. The stabilizer may also be adjusted to level the unit for transport.

The type of work to be done by the harrow will determine the type of adjustment to be made.

Observe the harrow while it is working and check if the dead furrow is being filled and the ground left level. If not, an adjustment will have to be made.

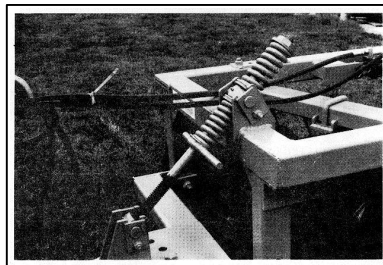

If the left blade of the rear gang is being "starved" for soil, move the rear gang slightly to the right or increase the rear gang cutting angle.

If the left blade of the rear gang is throwing too much soil, move the gang slightly to the left or decrease the rear gang cutting angle.

Changing the angle between the gangs will affect the penetration of the harrow. The wider the angle, the deeper the harrow will cut.

There are many factors which affect the way in which the soil will flow. Some factors are: moisture content of the soil, type of soil, speed of the tractor, depth of penetration, and working angle between the gangs. If any one of the conditions change, there will be a change in, the resulting disking job.

Move the rear gang laterally one or two inches, or change the angle one hole at a time when making an adjustment.

To check the quality of disking being done, make one complete round and pass the points where the observation was made.

DISK GANG ANGLE: The gangs may be set at cutting angles 17, 20, and 23 degrees, depending on soil conditions and job to be done. When conditions are near normal a setting between the two extremes is advisable for best operation. Use the set of holes in the main frame rails to select desired angles. The front gang angle can be increased by moving the gang forward. Moving the gang rearward will decrease the gang angle. Moving the rear gang forward will decrease the rear gang angle. Moving the rear gang to the rear will increase the rear gang cutting angle.

Increasing the cutting angle will increase penetration, soil pulverizing action, and power requirements. Decreasing the cutting angle will have the opposite effect. Remember, always retorque gang frame mount bolts after making adjustments.

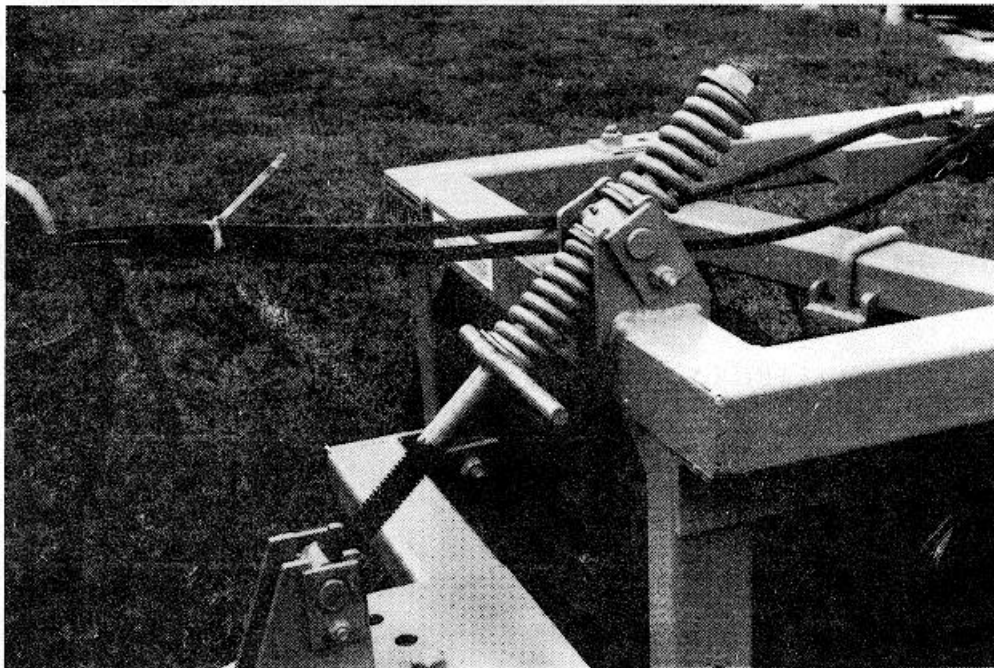

Disk as deep as necessary to do a thorough job but do not try to disk to an excessive depth. In most conditions, your AMCO harrow has ample weight for penetration. In other conditions, you may have a little more weight than you really need. Your harrow should be equipped with flotation tires for these conditions. 9.5L x 15 tires will be adequate for most conditions. You also need a good heavy duty, 4 x 8 hydraulic cylinder with stroke control. This will allow you to control your harrow cutting depth to meet all conditions. You should never allow soil to "bulldoze" ahead of or flow over the axle and spacer spools. Cutting depth should be controlled to avoid this situation. Maintaining proper cutting depth will have the following advantages:

1. Increased life of gang bearings.
2. Less strain on disk harrow frame. Therefore, the harrow will last longer.
3. Less load on your tractor engine and drive train.
4. Lower fuel consumption due to less load on tractor engine.
5. Less wheel slippage and less rear tractor tire wear due to lower load.
6. Higher tractor travel speeds due to less rear wheel slippage.

Therefore, by properly controlling the cutting depth, you can increase gang bearing life and cover more acres per day at a lower cost. In most cases it will not be necessary to reduce cutting depth by more than 1/2".

GANG LATERAL ADJUSTMENT: Front and rear gangs may be moved laterally for adjustments in extreme conditions. To make lateral gang adjustments, loosen the bolts that secure the gang frames to the main frame. Be sure to re-tighten the clamp bolts after making the adjustments.

SCRAPER ADJUSTMENT: Your harrow is equipped with heavy duty scrapers. The scrapers should be adjusted so that the blade of the scraper slightly touches the disk blade yet allows the gang to turn freely. Each scraper can be adjusted individually by loosening the carriage bolt and sliding the scraper to the desired position. Always re-tighten the carriage bolt.

OFFSETTING THE HARROW: The harrow drawbar may be adjusted so the left tractor wheel can be run in the furrow if that is desirable. Or the left hand tractor wheel may be operated to the right of this furrow, or uncut ground, by making the compensating adjustment on the harrow drawbar. The fields may be laid out so right turns are made by lifting the harrow out of the ground before making the turn.

When the harrow is adjusted so it disks in an extreme left offset position, the front gang will assume a much greater angle (with respect to forward travel) than the rear gang. The rear gang will have a relatively small angle with respect to forward travel.

The small angle of the rear gang makes it more difficult to fill the dead furrow, but the condition can be corrected by using a rear gang adjustment. Usually, the rear gang will have to be shifted to the left.

In general, when making a left offset, attempt to keep the amount of offset as small as possible.

The following points are important to remember when offsetting the harrow:

1. Offsetting to the left increases the angle of the front gang and decreases the angle of the rear gang.
2. Offsetting to the right decreases the angle of the front gang and increases the angle of the rear gang.

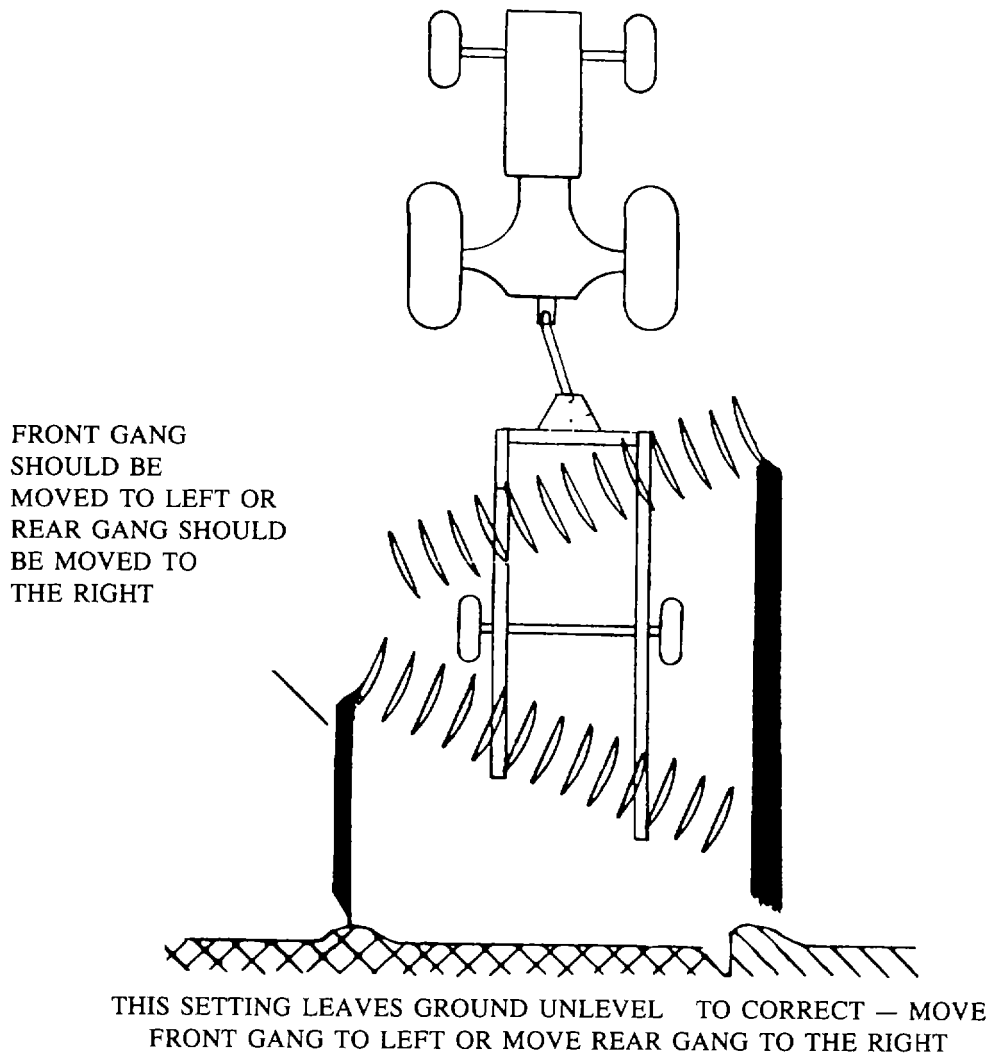

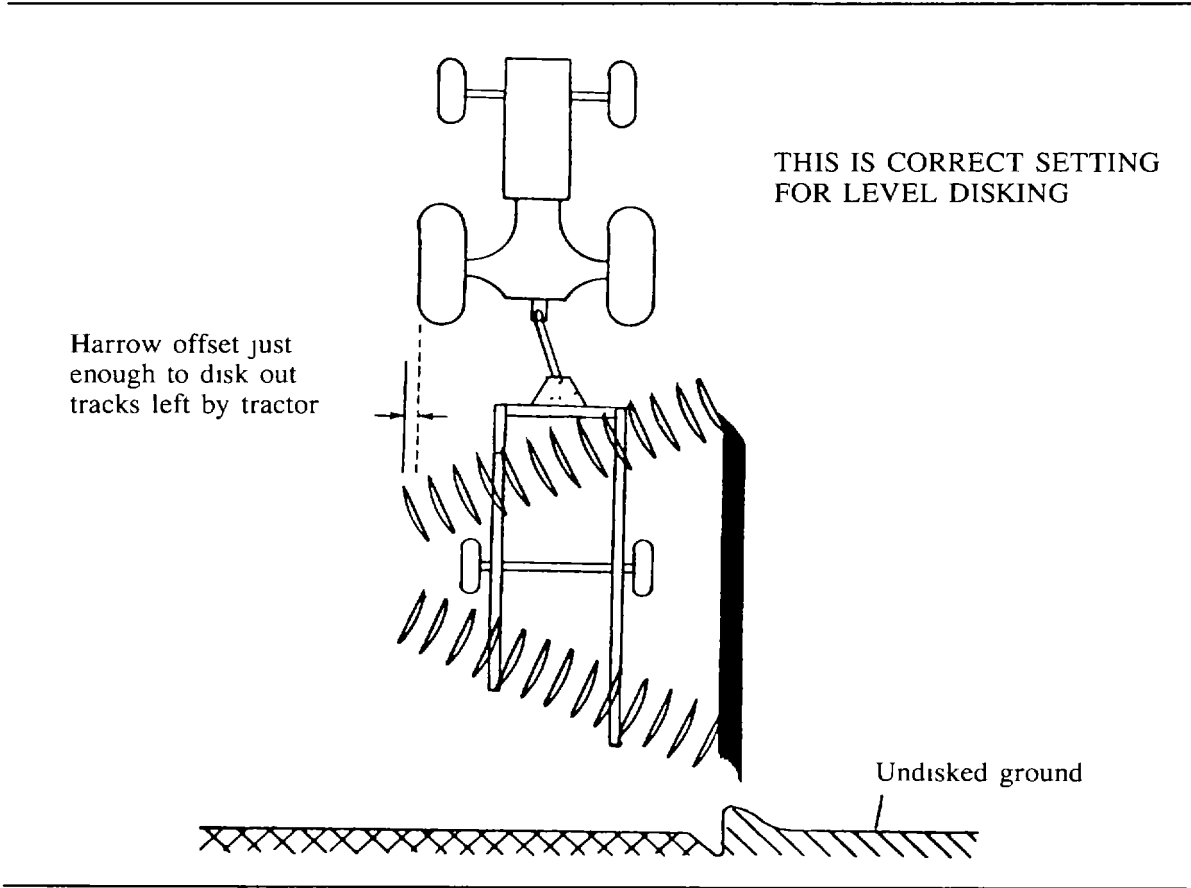
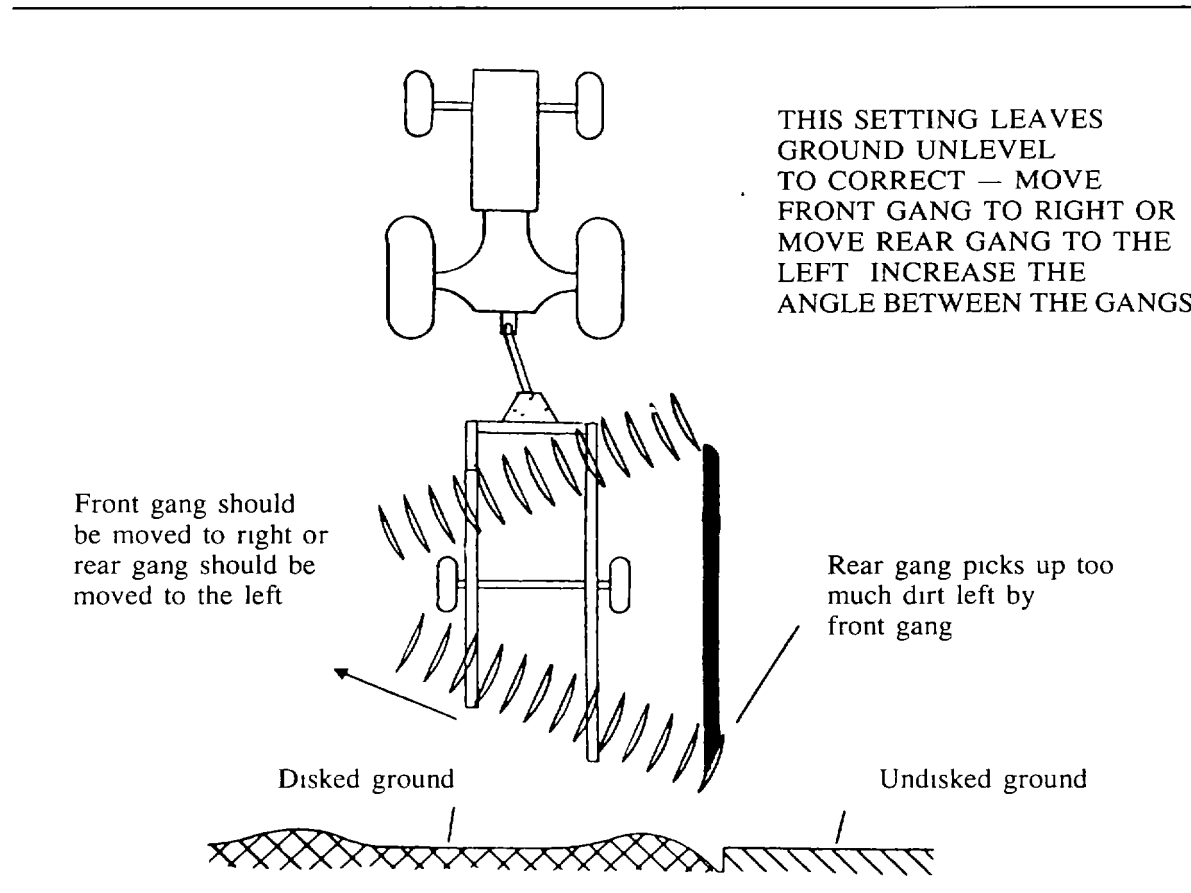

TRANSPORT PIN: When transporting the disk harrow, always lock it in transport position with the transport pin. If the hydraulic cylinder is to be removed from the disk harrow, the transport pin should be installed before attempting to remove the cylinder.

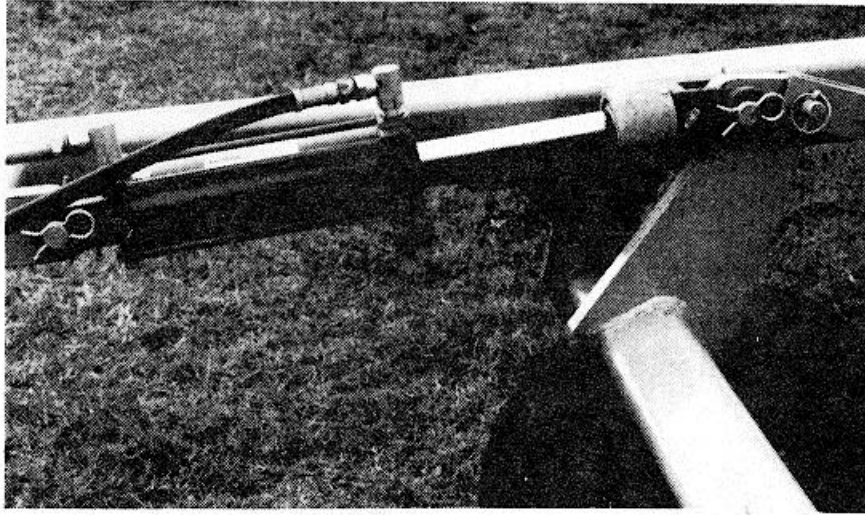

HYDRAULIC CYLINDER: Attach the rod end of the cylinder to the rockshaft lift arm and the butt end of the cylinder to the main frame as shown above. A heavy duty ASAE 4 x 8 hydraulic cylinder with stroke control is recommended for raising and lowering the disk harrow.

STORAGE: Proper storage will add to the life of your disk harrow, and assure its being in good condition for the next season. The following procedure is recommended:

1. Clean off all foreign matter, and lubricate the harrow.
2. Repaint the harrow where the original paint has worn off.
3. Coat the disk blades with a rust preventative.
4. Tighten all loose bolts and replace any damaged or missing parts.
5. All hydraulic cylinder rods should be fully retracted or coated with a rust preventative to prevent rusting in storage.

WARNING REFLECTORS: Attach a reflector with both red and amber reflective surfaces as near as possible to the extreme left rear part of the harrow. Mount the reflector so that the red surface is visible from the rear and the amber surface is visible from the front. Attach a red reflector as near as possible to the extreme right rear part of the harrow with the reflective surface visible from the rear.

SMV EMBLEM: The SMV (Slow Moving Vehicle) Emblem is a recommended attachment that should be added to your harrow. The SMV Emblem and warning reflectors can be purchased from your authorized AMCO dealer. A mounting bracket is located on the rear of the main frame for mounting a SMV Emblem.

WARNING LAMP: A warning lamp to be mounted on the extreme left hand rear of the harrow is available at your local AMCO dealer.



CAUTION When transporting farm implements on public roads after dusk, it is the responsibility of the operator to provide lighting and reflectors on the rear of the implement in accordance with your state law.



CAUTION When trailing the harrow over public roads, the SMV Emblem must be used, for protection of tractor and motor vehicle operators.

Maintenance of the F41

KEEP ALL BOLTS TIGHT.

1. Check before placing in service.
2. Visually inspect all bolts daily.
3. Check after first 50 hours or one week's operation.
4. Check each season.

KEEP WHEEL BEARINGS PROPERLY ADJUSTED.

1. Check often.
2. Clean and repack each season or every 300 hours.
3. Replace worn or damaged parts.
4. In disassembling and reassembling the wheel hub assemblies, care must be taken to not damage the grease seal lips. In reassembly, to seat the bearings, carefully tighten the hex nut until the hub drags. Rotate hub to help seat the bearing cups and cones. Re-tighten the hex nut until the hub drags, then back off the hex nut to the nearest slot and secure with cotter pin.

DO NOT RUN WITH LOOSE DISK BLADES.

Keep gang bolts tight! Tighten gang bolts to 800-1000 ft. lbs. of torque.

KEEP SCRAPERS PROPERLY ADJUSTED.

GREASE BEARINGS AND RETAINER PINS REGULARLY.

Grease gang bearings and rockshaft retainer pins every week or 50 hours, at the start of each season, and at the end of each season. Apply with low pressure, low volume hand grease gun. Use a good No. 2 gun grease (Lithium Base). Rotate gangs while greasing for best results.

CAUTION: Use care to prevent damage to seals.

DISK BLADE, BEARING, AND SPOOL REPLACEMENT.

1. Remove the nuts that hold the gang bearing housing trunnion clamps.
2. Remove clamps.
3. Raise the harrow and roll the gang away from the frame.
4. Remove the gang nut lock plate.
5. Remove the gang hex nut from the end of the shaft.
6. Slide off the bearings, spools, spacers, and blades.
7. Avoid thread damage.
8. Tear the entire gang down and clean all parts. Check disk axle for straightness. Bowed, bent, or worn axles must be replaced.
9. Check spacer spools for damage caused by running disk with loose gangs or hitting underground obstructions. Replace spool if it is damaged.
10. Carefully check all end bells. The large end must contact the disk blade around the entire circumference of the end bell. The small end must be smooth and perpendicular to the axle. The end bells must be replaced if they are cracked or worn on the surface adjacent to the bearing.
11. Check all the bearings on the gang. Running a harrow for one hour or more after a bearing failure will seriously damage other bearings on the gang. This damaged bearing will then fail within a few hours after the failed bearing has been replaced. Continued operation with this failed bearing will damage the new bearing thus it will fail after a few hours use. In most cases it will be best to replace all bearings on a gang when it is torn down for repairs. A triple lip sealed bearing should always be used for bearing replacement. Also, a regreasable type bearing should always be used.

12. To replace a bearing, the snap ring must be removed. The old bearing and Protect-O-Shield should then be pressed out of the housing. Clean and wash out old grease and carefully check the housing. Replace the housing if it is damaged. Check the Protect-O-Shields and replace if they are damaged before installing. Press the new bearing straight into the housing. Always press against the outer race of the bearing. NEVER press against the seal or inner race of the bearing. Check location of the grease hole in the outer race of the bearing. This hole must align with the grease groove in the bearing housing. Rotate the bearing in the housing after it is pressed in to be sure it turns freely. Install the other Protect-O-Shield. Install the snap ring in the housing.
13. After cleaning, checking, and replacing all damaged parts, the gang should be assembled. Be sure the grease fittings in the bearing housings face to the rear. Be sure the snap ring in the bearing housing is turned toward the convex (back) side of the disk blades. The 1-1/2" square gang bolt nut should be torqued to 800-1000 ft/lbs. The axle nut should be locked in place with the lock strap.
14. After the gang is assembled it should be attached to the harrow. The bearing risers should be carefully spaced to match the bearing housings. Poorly spaced bearing risers will overload the bearings and cause premature failure. The gang should be rotated 4 or 5 complete revolutions to be sure that all parts are aligned and the gang turns freely.
15. The bearings should be greased each week or every 50 hours of use with a good grade of clean, number 2, lithium soap base grease. Use of dirty grease or a grease with metallic additives will reduce bearing life. A hand operated grease gun should always be used. Excessive greasing will damage bearing seals.

Troubleshooting

Problem Symptom	Initial Procedures	Possible Causes (Solutions)
Poor penetration	Check for proper gang angle	Adjust gang angle to angle best suited for soil condition
Disk not cutting level Front to rear	Tractor speed Hitch adjustment not level	High-speed disking sometimes results in excessive lateral movement of the soil. This may leave an uneven surface behind the disk harrow known as "ridging" or "furling." In extremely hard ground, it may be necessary to shorten the stabilizer Spring stabilizer to force the front gang into the ground. In normal adjustment conditions, the stabilizer should be adjusted so that the disk harrow is level front to rear while disking
"Plugging" Dirt sticking to blades and spools	Check scraper adjustment	Improper scraper adjustment Ground too wet. Excess moisture in certain soils make it very difficult to keep from plugging. Give ground time to dry out.

NOTE: Read operating instructions and safety suggestions before using this equipment.

Assembly Chart

MODEL	MEASUREMENT "A"
F41 -18 Blade	12-1/4
F41 -20 Blade	16-3/4
F41-22 Blade	21-1/2
F41-24 Blade	26

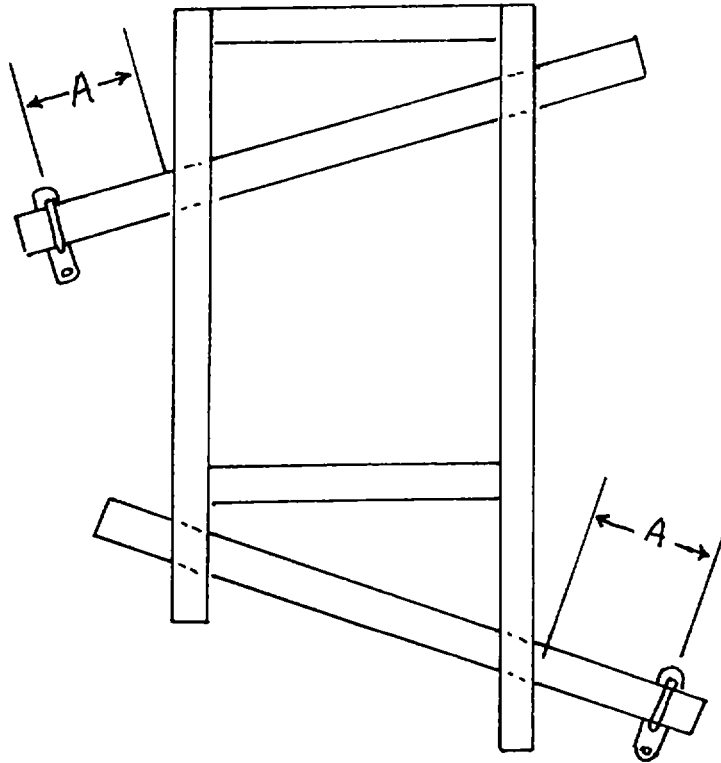

33/(34 blank)

**APPENDIX A
.REFERENCES
NOT APPLICABLE**

A-1(A-2 blank)

APPENDIX B

MAINTENANCE ALLOCATION CHART

Section I. INTRODUCTION

B-1. General.

This appendix provides a summary of the maintenance operations for the Disk Harrow. It authorizes categories of maintenance for specific maintenance functions on repairable items and components and the tools and equipment required to perform each function. This appendix may be used as an aid in planning maintenance operations.

a. This section provides a general explanation of all maintenance and repair functions authorized at various maintenance categories.

b. The Maintenance Allocation Chart (MAC) in Section II designates overall authority and responsibility for the performance of maintenance functions on the identified end item or component. The application of the maintenance functions to the end item or component will be consistent with the capacities and capabilities of the designated maintenance categories.

c. Section III lists the tools and test equipment (both special tools and common tool sets) required for each maintenance function as referenced from Section II.

d. Section IV contains supplemental instructions and explanatory notes for a particular maintenance function.

B-2. Maintenance Functions. Maintenance functions will be limited to and defined as follows:

a. Inspect. To determine the serviceability of an item by comparing its physical, mechanical, and/or electrical characteristics with established standards through examination (e.g., by sight, sound, or feel).

b. Test. To verify serviceability by measuring the mechanical, pneumatic, hydraulic, or electrical characteristics of an item and comparing those characteristics with prescribed standards.

c. Service. Operations required periodically to keep an item in proper operating condition, i.e., to clean (includes decontaminate, when required), to preserve, to drain, to paint, or to replenish fuel, lubricants, chemical fluids, or gases.

d. Adjust. To maintain or regulate, within prescribed limits, by bringing into proper or exact position, or by setting the operating characteristics to specified parameters.

e. Align. To adjust specified variable elements of an item to bring about optimum or desired performance.

f. Calibrate. To determine and cause corrections to be made or to be adjusted on instruments or test, measuring, and diagnostic equipments used in precision measurement. Consists of comparisons of two instruments, one of which is a certified standard of known accuracy, to detect and adjust any discrepancy in the accuracy of the instrument being compared.

g. Remove/Install. To remove and install the same item when required to perform service or other maintenance functions. Install may be the act of emplacing, seating, or fixing into position a spare, repair part, or module (component or assembly) in a manner to allow the proper functioning of an equipment or system.

h. Replace. To remove an unserviceable item and install a serviceable counterpart in its place. "Replace" is authorized by the MAC and is shown as the third position code of the SMR code.

i. Repair. The application of maintenance services,¹ including fault location/troubleshooting² removal/installation, and disassembly/assembly procedures,³ and maintenance actions,⁴ to identify troubles and restore serviceability to an item by correcting specific damage, fault, malfunction, or failure in a part, subassembly, module (component or assembly), end item, or system.

j. Overhaul. That maintenance effort (service/action) prescribed to restore an item to a completely serviceable/operational condition as required by maintenance standards in appropriate technical publications (i.e. DMWR). Overhaul is normally the highest degree of maintenance performed by the Army. Overhaul does not normally return an item to like-new condition.

k. Rebuild. Consists of those services/actions necessary for the restoration of unserviceable equipment to a like-new condition in accordance with original manufacturing standards. Rebuild is the highest degree of materiel maintenance applied to Army equipment. The rebuild operation includes the act of returning to zero those age measurements (hours/miles, etc.) considered in classifying Army equipment/components.

B-3. Explanation Of Columns In The MAC, Section II.

a. Column 1. Group Number. Column 1 lists functional group code numbers, the purpose of which is to identify maintenance significant components, assemblies, subassemblies, and modules with the next higher assembly. End item group number shall be "00."

b. Column 2 Component/Assembly. Column 2 contains the names of components, assemblies, subassemblies, and modules for which maintenance is authorized.

c. Column 3. Maintenance Function. Column 3 lists the functions to be performed on the item listed in column 2. (For a detailed explanation of these functions, see paragraph B-2.)

d. Column 4. Maintenance Category. Column 4 specifies, by the listing of a work time figure in the appropriate subcolumn(s), the category of maintenance authorized to perform the function listed in column 3. This figure represents the active time required to perform that maintenance function at the indicated category of maintenance. If the number or complexity of the tasks within the listed maintenance function vary at different maintenance categories, appropriate work time figures will be shown for each category. The work time figure represents the average time required to restore an item (assembly, subassembly, component, module, end item, or system) to a serviceable condition under typical field operating conditions. This time includes preparation time (including any necessary disassembly/ assembly time), troubleshooting/fault location time, and quality assurance/quality control time in addition to the time required to perform the specific tasks identified for the maintenance functions authorized in the maintenance allocation chart. The symbol designations for the various maintenance categories are as follows:

¹ Services - inspect, test, service, adjust, align, calibrate, and/or replace.

² fault locate/troubleshoot - the process of investigating and detecting the cause of equipment malfunctioning; the act of isolating a fault within a system or unit under test (UUT).

³ Disassemble/assemble - encompasses the step-by-step taking apart (or breakdown) of a spare/functional group coded item to the level of its least component identified as maintenance significant (i.e., assigned an SMR code) for the category of maintenance under consideration.

⁴ Actions - we/ding, grinding, riveting, straightening, facing, remachining, and/or resurfacing.

- C Operator/Crew
- O Unit Maintenance
- F Direct Support Maintenance
- H General Support Maintenance
- D Depot Maintenance

e. Column 5. Tools and Equipment. Column 5 specifies, by code, those common tool sets (not individual tools) and special tools, TMDE, and support equipment required to perform the designated function.

f. Column 6. Remarks. This column shall, when applicable, contain a letter code, in alphabetic order, which shall be keyed to the remarks contained in section IV.

B-4. Explanation Of Columns In Tool And Test Equipment Requirements, Section III.

a. Column 1. Reference Code. The tool and test equipment reference code correlates with a code used in the MAC, section II, column 5.

b. Column 2. Maintenance Category. The lowest category of maintenance authorized to use the tool or test equipment.

c. Column 3. Nomenclature. Name or identification of the tool or test equipment.

d. Column 4. National Stock Number. The National Stock Number of the tool or test equipment.

e. Column 5. Tool Number. The manufacturer's part number.

B-5. Explanation Of Columns In Remarks, Section IV.

a. Column 1. Reference Code. The code recorded in column 6, Section II.

b. Column 2. Remarks. This column lists information pertinent to the maintenance function being performed as indicated in the MAC, Section II.

APPENDIX B

Section II. MAINTENANCE ALLOCATION CHART

(1) GROUP NUMBER	(2) COMPONENT/ ASSEMBLY	(3) MAINTENANCE FUNCTION	(4) MAINTENANCE LEVEL					(5) TOOLS AND EQUIPMENT	(6) REMARKS
			UNIT		DS	GS	DEPOT		
			C	O	F	H	D		
001	Disk Harrow	Inspect	0.5						
		Replace		2.0			1		
		Repair			4.0		2		
002	Main Frame, Rockshaft and Pull Tongue	Inspect	0.5						
		Replace		2.0			1		
		Repair			3.0		2		
0021	Clamp, Trunnion	Replace		2.0			1		
0022	Swivel, Stabilizer	Replace		3.0			2		
0023	Assy, Stabilizer Rod	Inspect	0.5						
		Replace		2.0			1		
		Repair		3.0			2		
0024	Spring	Inspect.	0.1						
		Replace	2.0				1		
0025	Swivel	Inspect		0.1					
		Replace		2.0			1		
0026	Pin, Roll	Inspect	0.3						
		Replace		2.0			2		
0027	Strap	Replace		1.0					
0028	Pin, Retainer	Replace		0.5			2		
0029	Assy, Transport Pin	Replace							
00201	Assy, Transport Strap	Replace		0.5			2		
00202	Bushing, Bronze	Inspect	0.3						
		Replace		1.0			3		
		Service	0.1						
00203	Jack, Parking	Repair		2.0			2		
		Replace		2.0			1		
		Service		0.2			1		
003	Hub and Wheel	Inspect	0.1						
		Repair			2.0		2		
		Replace		1.0			2		

APPENDIX B (CONT.)

Section II. MAINTENANCE ALLOCATION CHART

(1) GROUP NUMBER	(2) COMPONENT/ ASSEMBLY	(3) MAINTENANCE FUNCTION	(4) MAINTENANCE LEVEL					(5) TOOLS AND EQUIPMENT	(6) REMARKS
			UNIT		DS	GS	DEPOT		
			C	O	F	H	D		
0031	Support, Wheel	Service		0.5				1	
		Replace		2.0				2	
0032	Seal, Grease	Replace		0.5				2	
0033	Cone, Inner	Replace		0.5				2	
0034	Hub	Replace		0.5				2	
0035	Cup, Inner	Replace		1.0				1	
0036	Cup, Outer	Replace		0.4				2	
0037	Cone, Outer	Replace		0.2				1	
0038	Cap, Hub	Replace	0.3					1	
0039	Wheel	Replace		1.0				2	
004	Rear Gang and Frame	Inspect		0.1					
		Replace		2.0				2	
		Repair			3.0			2	
0041	Bearing Riser	Replace		1.0				2	
0042	Bumper Washer, Drilled and Tapped	Repair		2.0				2	
		Replace		1.0				2	
0043	End Bell, Small	Replace		1.0					
0044	End Bell, Large	Replace		1.0				2	
0045	Sub Assy., Housing and Bearing	Repair		2.0				2	
		Replace		1.0				1	
0046	End Gang Washer	Replace		0.4				1	
0047	Spacer Plate	Replace		0.4				1	
0048	Bearing Plate	Replace		0.4				2	
0049	Lock Plate	Replace		0.5				2	
00401	Scraper Bar	Replace		1.0				1	
00402	Assy., Scraper L.H.	Inspect	0.5						
		Replace		1.0				2	

APPENDIX B

Section II. MAINTENANCE ALLOCATION CHART

(1) GROUP NUMBER	(2) COMPONENT/ ASSEMBLY	(3) MAINTENANCE FUNCTION	(4) MAINTENANCE LEVEL					(5) TOOLS AND EQUIPMENT	(6) REMARKS
			UNIT		DS	GS	DEPOT		
			C	O	F	H	D		
005	Front Gang and Frame	Inspect		0.5					
		Service		0.5				1	
		Repair			2.0			2	
0051	"U" Bolt	Replace		1.0				2	
		Inspect		0.1					
0052	Spacer Spool	Replace		1.0				2	
		Inspect		0.1					
0053	Assy., Scraper R.H.	Replace			1.0			2	
		Inspect		0.1					
0054	Gang Bolt 5 Blade	Replace		1.0				2	
0055	Gang Bolt 6 Blade	Inspect	0.1						
		Replace		1.0				2	

APPENDIX B

**Section III. TOOL AND TEST EQUIPMENT REQUIREMENTS
MAINTENANCE ALLOCATION CHART**

(1) TOOL/TEST EQUIP. REF CODE	(2) MAINTENANCE CATEGORY	(3) NOMENCLATURE	(4) NSN	(5) TOOL NUMBER
1	O	Tool Kit, General Mechanics: Automotive	5180-00-177-7033	
2	O	Shop Equipment, Automotive Maintenance and Repairs, Organizational Maintenance, Common No. 1, Less Power	4910-00-754-0654	
3	F	Shop Equipment, General Purpose Repair, Semi-Trailer Mounting	4940-00-287-4894	

APPENDIX B
Section IV. REMARKS FOR
MAINTENANCE ALLOCATION CHART

NOT APPLICABLE

APPENDIX C

**COMPONENTS OF END ITEM LIST/BASIC ISSUE ITEMS LIST
NOT APPLICABLE**

C-1/(C-2 blank)

**APPENDIX D
ADDITIONAL AUTHORIZED LIST
NOT APPLICABLE**

D-1/(D-2 blank)

**APPENDIX E
EXPENDABLE SUPPLIES AND MATERIALS LIST**

TO BE PROVIDED AT A LATER DATE.

E-1/(E-2 blank)

By Order of the Secretary of the Army:

GORDON R. SULLIVAN
General, United States Army
Chief of Staff

Official:

MILTON H. HAMILTON
Administrative Assistant to the
Secretary of the Army
00703

DISTRIBUTION:

To be distributed in accordance with Special Distribution List.

RECOMMENDED CHANGES TO EQUIPMENT TECHNICAL PUBLICATIONS

 <p style="margin-left: 20px;"><i>THEN...JOT DOWN THE DOPE ABOUT IT ON THIS FORM. CAREFULLY TEAR IT OUT, FOLD IT AND DROP IT IN THE MAIL.</i></p>		SOMETHING WRONG WITH PUBLICATION	
		FROM: (PRINT YOUR UNIT'S COMPLETE ADDRESS)	
		DATE SENT	
PUBLICATION NUMBER		PUBLICATION DATE	PUBLICATION TITLE
BE EXACT PIN-POINT WHERE IT IS			
PAGE NO.	PARA-GRAPH	FIGURE NO.	TABLE NO.
IN THIS SPACE, TELL WHAT IS WRONG AND WHAT SHOULD BE DONE ABOUT IT.			
PRINTED NAME, GRADE OR TITLE AND TELEPHONE NUMBER		SIGN HERE	

DA FORM 2028-2
1 JUL 79

PREVIOUS EDITIONS ARE OBSOLETE.

P.S.--IF YOUR OUTFIT WANTS TO KNOW ABOUT YOUR RECOMMENDATION MAKE A CARBON COPY OF THIS AND GIVE IT TO YOUR HEADQUARTERS.

The Metric System and Equivalents

Linear Measure

1 centimeter = 10 millimeters = .39 inch
 1 decimeter = 10 centimeters = 3.94 inches
 1 meter = 10 decimeters = 39.37 inches
 1 dekameter = 10 meters = 32.8 feet
 1 hectometer = 10 dekameters = 328.08 feet
 1 kilometer = 10 hectometers = 3,280.8 feet

Weights

1 centigram = 10 milligrams = .15 grain
 1 decigram = 10 centigrams = 1.54 grains
 1 gram = 10 decigrams = .035 ounce
 1 decagram = 10 grams = .35 ounce
 1 hectogram = 10 decagrams = 3.52 ounces
 1 kilogram = 10 hectograms = 2.2 pounds
 1 quintal = 100 kilograms = 220.46 pounds
 1 metric ton = 10 quintals = 1.1 short tons

Liquid Measure

1 centiliter = 10 milliliters = .34 fl. ounce
 1 deciliter = 10 centiliters = 3.38 fl. ounces
 1 liter = 10 deciliters = 33.81 fl. ounces
 1 dekaliter = 10 liters = 2.64 gallons
 1 hectoliter = 10 dekaliters = 26.42 gallons
 1 kiloliter = 10 hectoliters = 264.18 gallons

Square Measure

1 sq. centimeter = 100 sq. millimeters = .155 sq. inch
 1 sq. decimeter = 100 sq. centimeters = 15.5 sq. inches
 1 sq. meter (centare) = 100 sq. decimeters = 10.76 sq. feet
 1 sq. dekameter (are) = 100 sq. meters = 1,076.4 sq. feet
 1 sq. hectometer (hectare) = 100 sq. dekameters = 2.47 acres
 1 sq. kilometer = 100 sq. hectometers = .386 sq. mile

Cubic Measure

1 cu. centimeter = 1000 cu. millimeters = .06 cu. inch
 1 cu. decimeter = 1000 cu. centimeters = 61.02 cu. inches
 1 cu. meter = 1000 cu. decimeters = 35.31 cu. feet

Approximate Conversion Factors

<i>To change</i>	<i>To</i>	<i>Multiply by</i>	<i>To change</i>	<i>To</i>	<i>Multiply by</i>
inches	centimeters	2.540	ounce-inches	Newton-meters	.007062
feet	meters	.305	centimeters	inches	.394
yards	meters	.914	meters	feet	3.280
miles	kilometers	1.609	meters	yards	1.094
square inches	square centimeters	6.451	kilometers	miles	.621
square feet	square meters	.093	square centimeters	square inches	.155
square yards	square meters	.836	square meters	square feet	10.764
square miles	square kilometers	2.590	square meters	square yards	1.196
acres	square hectometers	.405	square kilometers	square miles	.386
cubic feet	cubic meters	.028	square hectometers	acres	2.471
cubic yards	cubic meters	.765	cubic meters	cubic feet	35.315
fluid ounces	milliliters	29.573	cubic meters	cubic yards	1.308
pints	liters	.473	milliliters	fluid ounces	.034
quarts	liters	.946	liters	pints	2.113
gallons	liters	3.785	liters	quarts	1.057
ounces	grams	28.349	liters	gallons	.264
pounds	kilograms	.454	grams	ounces	.035
short tons	metric tons	.907	kilograms	pounds	2.205
pound-feet	Newton-meters	1.356	metric tons	short tons	1.102
pound-inches	Newton-meters	.11296			

Temperature (Exact)

°F	Fahrenheit temperature	5/9 (after subtracting 32)	Celsius temperature	°C
----	---------------------------	-------------------------------	------------------------	----

PIN: 069400-000